

CL400[®] Magnetic 1

PAGE

Installation Instructions for CL400 Magnetic Bi-Parting Key Locking Handles

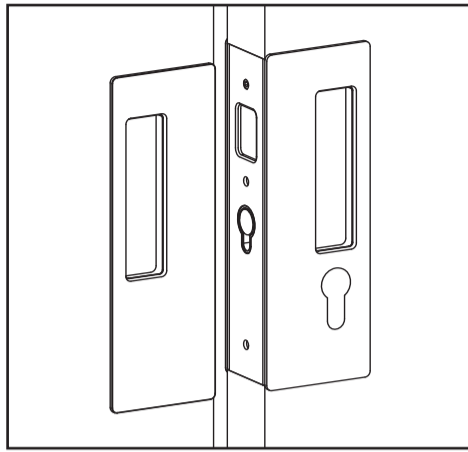

Before you Start:

- These handles have been manufactured to specifications which **cannot** be altered by the installer. These include:
 - Handle type:** the CL400 handle is available in *Passage*, *Privacy*, *Key Locking* and *Bi-Parting* versions. You have purchased the **Bi-Parting Key Locking** version.
 - Configuration:** the Key Locking handle configurations include; *Key/Key*, *Key one Side* and *Key/Snib*.
 - Handing**
 - Door thickness range:** the CL400 handle is available in four door thickness ranges. These are: 34-40mm, 40-46mm, 46-52mm and 52-58mm (1-3/8" to 1-9/16", 1-5/8" to 1-3/4", 1-13/16" to 2" and 2-1/16" to 2-1/4").
 - Security:** the CL400 handle varies in security depending on the version and configuration. The CL400 Bi-Parting Key Locking configuration provides low level security. It is important to note that **the CL400 handle should not be installed in situations where a high level of security is required, e.g. external entry points or high security internal doorways.**
- Refer to the information printed on the *Side Handle* and *Chassis* boxes to ensure you have purchased handles with the correct specifications for your situation. **If the specifications are incorrect you will need to exchange the handles.**
- Component drawings have been provided. Please familiarise yourself with the components and check the package to ensure nothing is missing. **Note: Components may vary slightly between configurations.**
- To ensure the handles latch accurately, it is essential that the doors are adjusted for height and are parallel with the closing jamb when closed **before** installing the handles.
- The CL400 is a metric handle. **Accurate measurements are shown in millimetres. Conversions to inches are approximate.**

Door Preparation

- Mark a line on the face of the doors where the centre of the handles are to be positioned. Align the centre line on the *door cut out template* with the centre line on the door. Follow the instructions on the template. Repeat cut out for both doors.

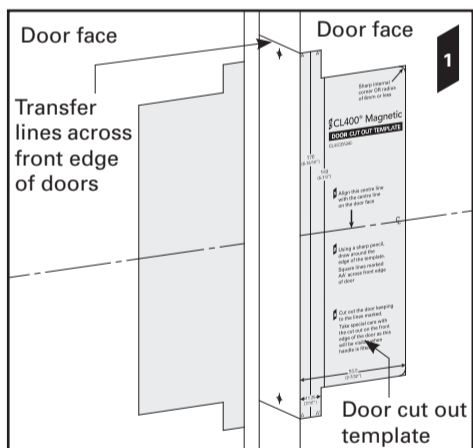

- Mark two holes in the centre of the door thickness in the positions shown. Using these marks, drill two 2.5mm (3/32") diameter holes to a depth of 35mm (1-3/8"). Repeat holes for both doors.

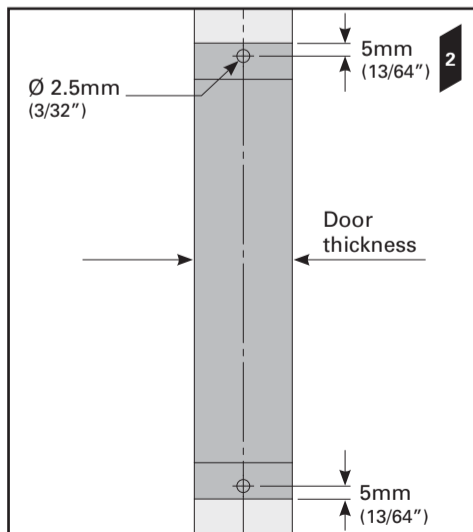

Fitting the Bi-Parting Mate

- The Bi-Parting chassis contains a strong magnet. **Read the warning on page 2 before continuing.** Remove the *Bi-Parting chassis* from its packaging. Remove the *face plate screw* and *face plate* from the chassis. Align the chassis with the centre of the door thickness. Screw the chassis to the door (using the two *chassis mounting screws*) through the slotted holes at the top and bottom of the chassis. **DO NOT** fully tighten the screws. Realign the chassis with the centre of the door thickness. When happy with the chassis position, fully tighten the screws.

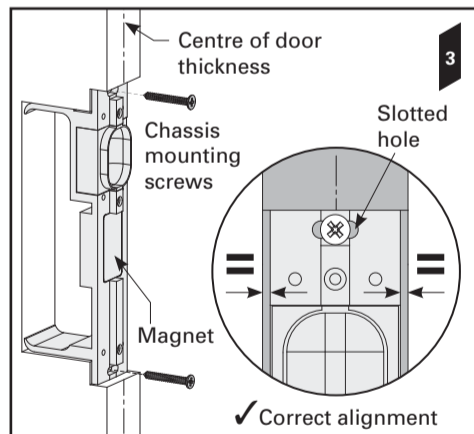

- Fit the 6x *side handle to chassis screws*. Leave a 3mm gap (1/8") between the underside of the screw head and the chassis.

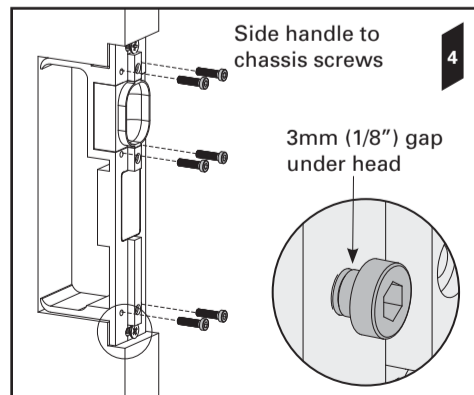

3
PAGE

IMPORTANT: Install THIS handle FIRST

Component Drawings - Bi-Parting Mate

Bi-Parting Side Handle Box

- a Bi-Parting Side Handle (Left)
- b Bi-Parting Side Handle (Right)

Bi-Parting Chassis Box

- c Bi-Parting Face Plate
- d Bi-Parting Chassis
- e Magnet
- f Chassis Mounting Screws (2)
- g Side Handle to Chassis Screws (6)
- h Handle Face Plate Screws (3)

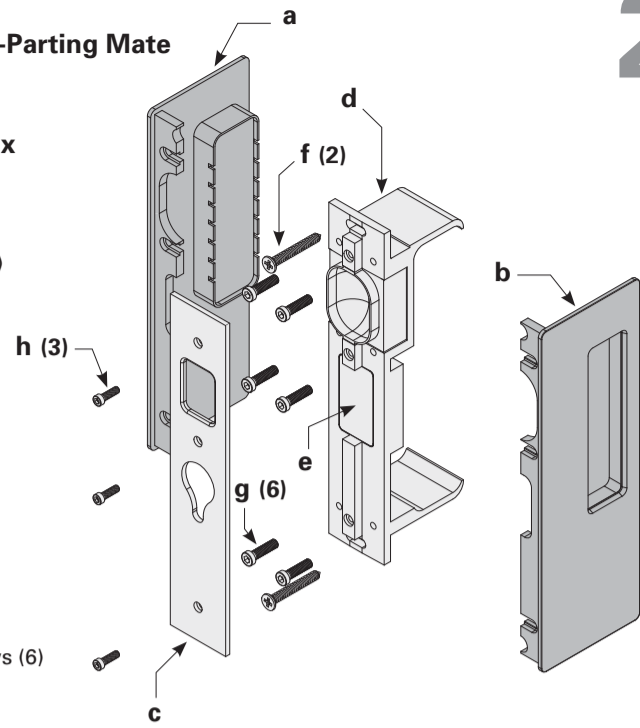

Tools (contained in Key Locking Chassis Box)

- i CL400 Allen Key (used for all machine screws)

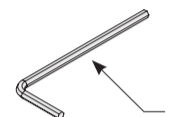

WARNING: THE BI-PARTING CHASSIS CONTAINS A STRONG MAGNET

IRON FILINGS - Magnets will attract shavings from iron or ferrous metals which may be hard to remove. Keep magnets a safe distance away from these materials.

DANGER FOR CHILDREN - Magnets may cause serious injury if swallowed. Keep out of reach of children. **CRUSHING, BLISTERS AND CUTS** - Fingers may become caught between magnets resulting in crushing, blisters or cuts.

BREAKING OR CHIPPING - It is possible that magnets could chip or shatter on contact, resulting in chips flying off at high speed into someone's eye. Chips can also be very sharp - treat them as you would broken glass.

MAGNETICALLY SENSITIVE ITEMS - Keep a safe distance between the magnet and all objects that can be damaged by magnetism (e.g. mechanical watches, pacemakers, cell phones etc.).

DISPOSAL - Magnets should be disposed of carefully and in accordance with your local regulations.

Fitting the Bi-Parting Mate

- Fit one of the *Bi-Parting side handles* (left OR right) to the chassis by sliding the front flange of the handle under the heads of the 3x *side handle to chassis screws*. Tighten the screws.

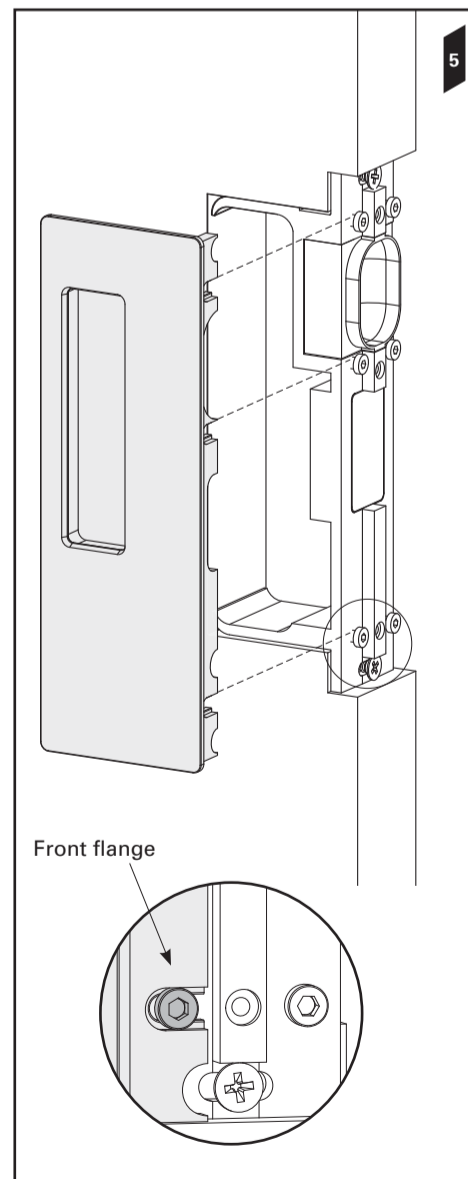

- Fit the remaining Bi-Parting side handle to the chassis and tighten the side handle screws.

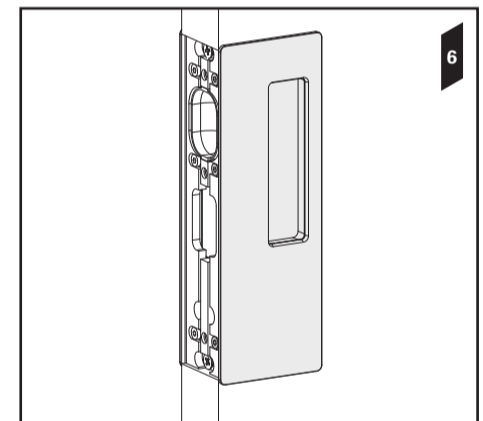

- Fit the *Bi-Parting face plate* to the chassis using the 3x *handle face plate screws*.

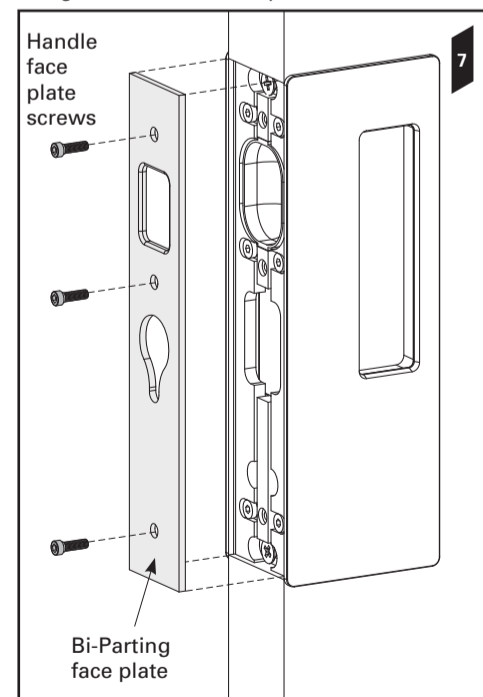

Go to page 5 (overleaf) →

2
PAGE

4
PAGE

Component Drawings - Key Locking Handle

Key Locking Side Handle Box

- j** Key Locking Side Handle (Left)
- k** Key Locking Side Handle (Right)

Key Locking Chassis Box

- l** Key Locking Face Plate
- m** Key Locking Chassis
- n** Plunger
- o** Shroud
- p** Plunger Nut
- q** Spring Reservoirs (2)
- r** Chassis Mounting Screws (2)
- s** Side Handle to Chassis Screws (6)
- t** Handle Face Plate Screws (3)
- u** Locking Cylinder
- v** Locking Cylinder Screw

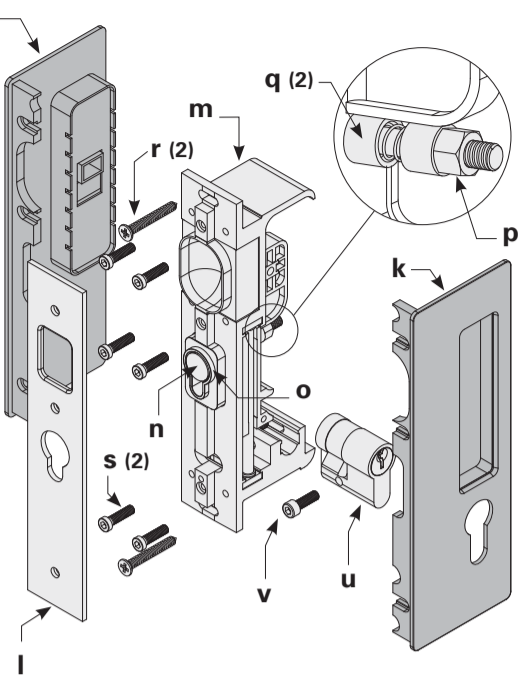

Note: Components will vary between the 'Key One Side', 'Key/Key' and 'Key/Snib' versions.

Tools (contained in Key Locking Chassis Box)

- w** Plunger Adjustment Spanners (2)
- x** Locking Cylinder Allen Key

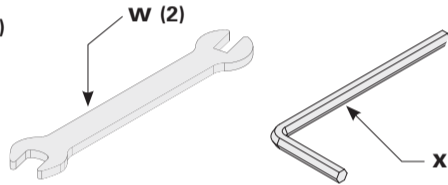

Fitting the Locking Cylinder

13. Slide the locking cylinder until it is flush with the face of the side handle. Fully tighten the locking cylinder screw.

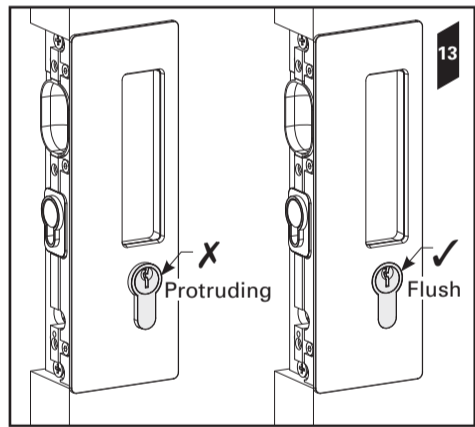

Adjusting the Plunger

14. Manually push the plunger in the key locking chassis forward until there is no gap between spring reservoir one (SR1) and spring reservoir two (SR2). Restrain the plunger nut using the large end of one of the supplied spanners.

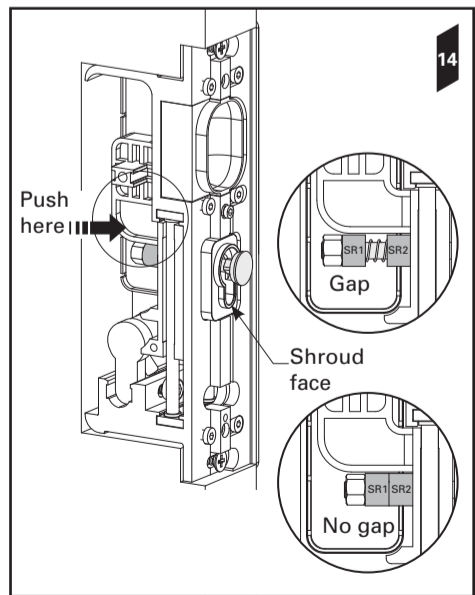

15. Place the small end of the second spanner across the flats under the head of the plunger. Keep the spanner restraining the plunger nut stationary while turning the second spanner clockwise.

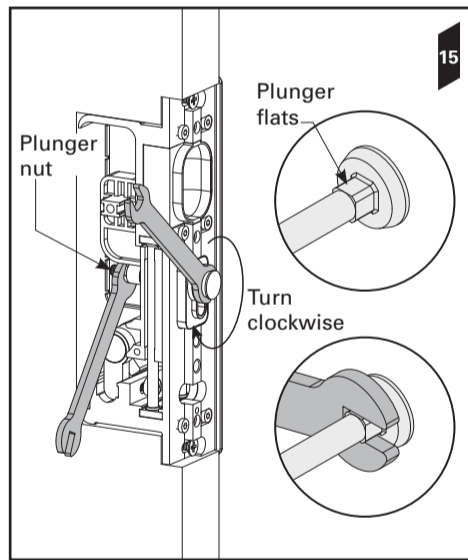

16. Continue to turn the spanner until there is no longer a gap between the spanner and the shroud face. Now turn the spanner anti clockwise half a turn. The plunger should now be adjusted correctly. Check the action by sliding the doors closed and locking them using the key. Adjust if necessary.

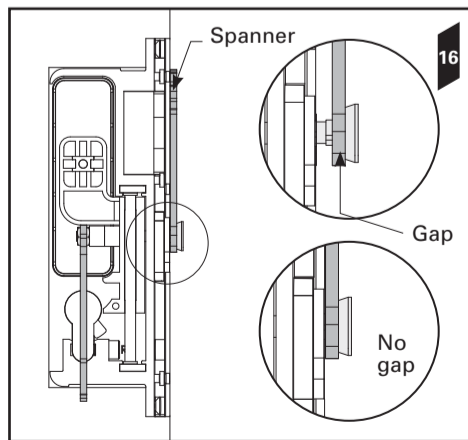

Fitting the Key Locking Handle

8. Remove the key locking chassis from its packaging. Remove the face plate screw and face plate from the chassis.

Align the chassis with the centre of the door thickness. Screw the chassis to the door (using the two chassis mounting screws) through the slotted holes at the top and bottom of the chassis. **DO NOT** fully tighten the screws.

Realign the chassis with the centre of the door thickness. When happy with the chassis position, fully tighten the screws.

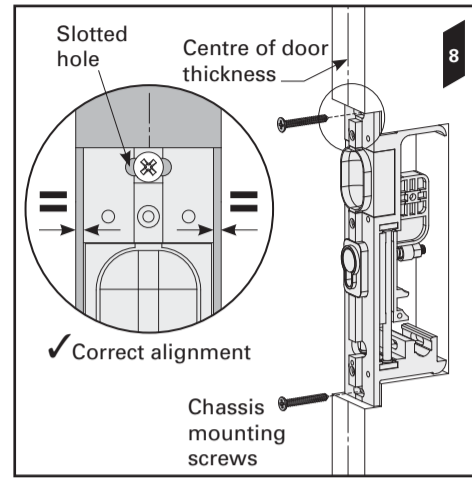

9. Fit the 6x side handle to chassis screws. Leave a 3mm gap (1/8") between the underside of the screw head and the chassis.

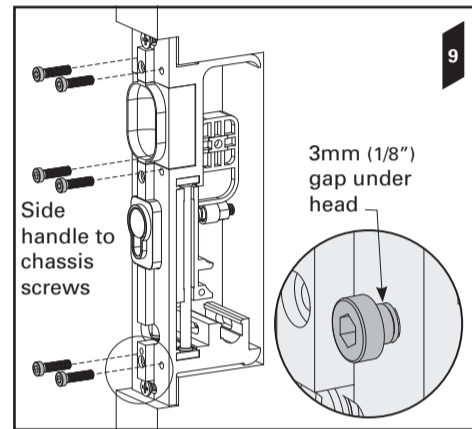

Fitting the Remaining Side Handle

17. Fit the remaining side handle to the chassis. If the side handle contains a snib you will need to:

- a. Align the recess in the back of the snib button with the arm of the locking slider.
- b. Slide the front flange of the handle under the heads of the three screws. Tighten the screws.

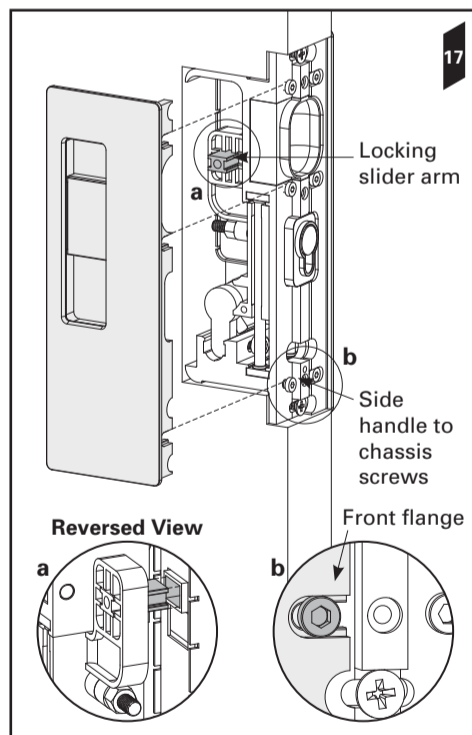

© Cavity Sliders Limited. CAVILOCK® CL400® (O.D. 2013) PRIVACY BIPARTING. 60913/CL400ZA932 - 06.2018
All copyright and other property in this document is reserved by Cavity Sliders Limited. Details and specifications are subject to change without notice. Whilst all care is taken to ensure the accuracy of all information, no responsibility will be accepted for any errors or omissions. © CS FOR DOORS, CS CAVITY SLIDERS and CAVILOCK are Registered Trademarks. Patents pending.



10. Fit the key locking side handle with the keyhole cut out to the chassis by sliding the front flange of the handle under the heads of the 3x side handle to chassis screws. Tighten the screws.

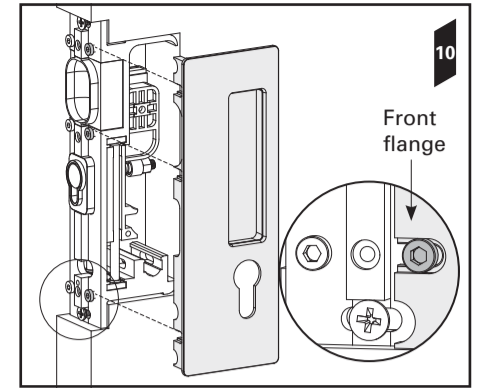

Fitting the Locking Cylinder

11. Insert the locking cylinder into the chassis.

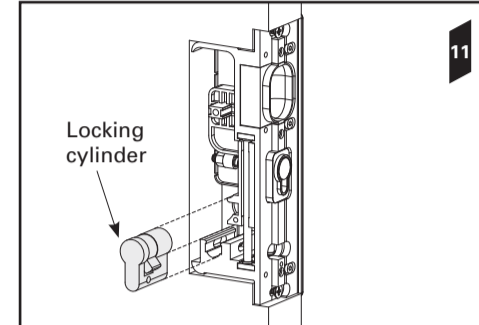

12. Secure the locking cylinder using the locking cylinder screw. **DO NOT** fully tighten the screw.

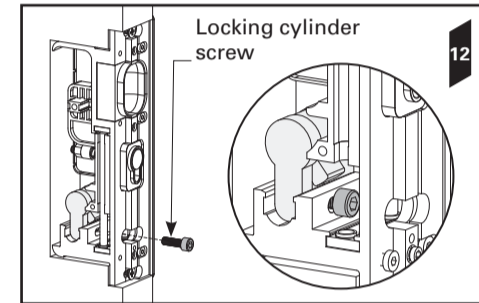

18. If installing a 'Key/Key' handle you may need to adjust the position of the locking cylinder. To do so, insert the locking cylinder Allen key through the slotted hole in the chassis. Loosen the screw and slide the cylinder into the desired position. Tighten the screw.

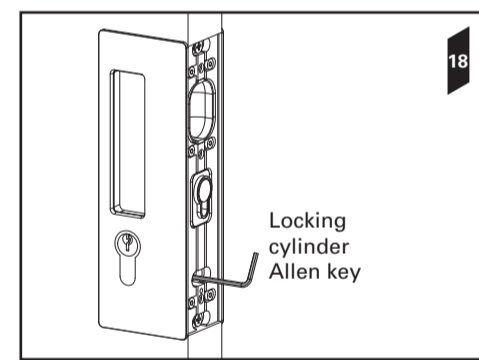

19. Fit the locking face plate to the chassis using the 3x handle face plate screws.

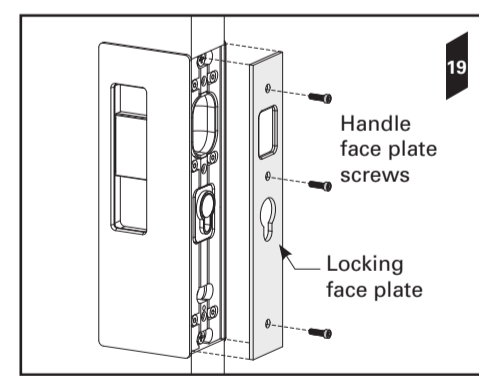

Cavity Sliders Limited
Auckland Head Office
5 - 7 Rakino Way
Mt Wellington
Auckland, NZ
T +64 9 276 0800
F +64 9 276 2525
info@csfordoors.co.nz

www.csfordoors.co.nz
www.cavitysliders.com.au
www.cavitysliders.com