



DuPont™  
**StraightFlash**

DuPont™  
**StraightFlash VF**

DuPont™  
**FlexWrap™ NF**

# DUPONT SELF-ADHERED FLASHING SYSTEMS INSTALLATION GUIDELINES

FOR BUILDINGS GREATER THAN 4 STORIES AND HIGH PERFORMANCE INSTALLATIONS OF ANY HEIGHT

REVISION 6/18

# DuPont Self-Adhered Flashing Systems Installation Guidelines

## Table of Contents

Note .....	2
Applicable Products .....	3
Warranty .....	3
General Instructions .....	3
Key Installation Requirements for Drainable Window / Door Installation Under the Limited Product and Labor Warranty .....	4
<b>Installation Methods for DuPont Flashing Systems products</b>	
<b>AFTER DuPont™ Tyvek® Air and Water Barrier is Installed.....</b>	<b>6</b>
Non-Flanged Window .....	6
Non-Flanged Window with Lintel and Brick Facade .....	14
Brick Mold Window .....	26
Integral Flanged Window.....	33
Non-Flanged Window Using DuPont™ StraightFlash™ VF .....	39
Store front Window on Slab .....	46
Store front Window on Knee Wall .....	52
Alternate Flanged Window Detail Aligned with FMA/AAMA 100-12 (Method A).....	59
Alternate Flanged Window Detail Aligned with FMA/AAMA 100-12 (Method B).....	65
Alternate Flanged Window Detail Aligned with FMA/AAMA 100-12 (Method C).....	71
<b>Installation Instructions for Through Wall Flashing .....</b>	<b>77</b>
Through Wall Flashing – DuPont™ Tyvek® Interface .....	77
Base of wall .....	77
Shelf angle .....	77
Parapet wall with brick.....	78
Penetrations.....	79
Proper overlap for water management.....	83

## Note

This installation guideline outlines recommended installation techniques and details for DuPont™ self-adhered flashing products and where applicable, DuPont™ Tyvek® CommercialWrap and/or DuPont™ Tyvek® CommercialWrap D, referred to in this document as DuPont™ Tyvek® air and water barriers.

# DuPont Self-Adhered Flashing Systems Installation Guidelines

## Applicable Products

### DuPont™ Self-Adhered Flashing Systems products

PRODUCT	WIDTH
DuPont™ FlexWrap™ NF	6 in 9 in
DuPont™ FlexWrap™ EZ	2.75 in
DuPont™ StraightFlash™	4 in 9 in
DuPont™ StraightFlash™ VF	6 in
DuPont™ Flashing Tape	4 in 6 in 9 in 12 in

### Required Materials Based on Project Requirements, Details, and Specifications\*

PRODUCT
DuPont™ Adhesive/Primer
DuPont™ Tyvek® Tape
DuPont™ Tyvek® Wrap Cap Fasteners or recommended fastening system
DuPont™ Sealant for Tyvek® Fluid Applied System†
DuPont™ Window & Door Foam
Backer Rod
Brushes for Surface Preparation
J-Roller
"L" shaped back dam is a 3/4" corner guard (used on interior gypsum)
Sealant*

\*Apply per manufacturers' guidelines. For non DuPont products, DuPont assumes no liability in use of recommended products; installers need to evaluate suitability of recommended products in their end-use applications.

†Refer to the *DuPont™ Tyvek® Fluid Applied Flashing Installation Guidelines* (K-29397) for more information about the use of DuPont™ Fluid Applied products with DuPont™ Tyvek® air and water barriers.

## Warranty

Please refer to the [DuPont Weatherization Products 10-Year Limited Warranty for Buildings Greater Than 4 Stories](#). For buildings less than 5 stories, and low-rise multi-family buildings less than 6 stories, please refer to the [DuPont Weatherization Products 10-Year Limited Warranty for Buildings Less Than 5 Stories and Low-Rise Multi-Family Residential Buildings Less Than 6 Stories](#).

## General Instructions

DuPont™ self-adhered flashing products should be installed on clean, dry surfaces that are free of frost. Wipe surfaces to remove moisture, dirt, grease and other debris that could interfere with adhesion.

Apply pressure along entire surface of flashing for a good bond using firm hand pressure, J-roller, or alternate tool without sharp edges (such as a plastic carpet tuck tool) to assist with application of uniform pressure during installation of DuPont™ self-adhered flashing systems products.

Remove all wrinkles and bubbles by smoothing surface and repositioning as necessary.

When flashing the sill area for windows and doors, DuPont recommends the use of 6" wide DuPont™ FlexWrap™ NF for 2" x 4" framing and 9" wide DuPont™ FlexWrap™ NF for 2" x 6" framing. When rigid back dams are required or desired, an option would be to use a ¾" corner guard (back dam) cut to the length of the sill and nail into place on the interior edge of the sill prior to installation of 9" wide DuPont™ FlexWrap™ NF. Then install 9" wide DuPont™ FlexWrap™ NF over sill and corner guard back dam.

Before applying 3" DuPont™ Tyvek® Tape, surfaces should be dry and clean. During installation apply firm, even pressure with hand or "J" roller.

In lieu of temporarily taping, DuPont™ Tyvek® flaps at window head and jambs can be tucked under the DuPont™ Tyvek® air and water barrier.

3" DuPont™ Tyvek® Tape should not be used to terminate DuPont™ Tyvek® flaps at window jambs and head when the building envelope design requirements exceed ASTM E1677, 65 mph equivalent structural load and 15 mph equivalent wind-driven rain water infiltration resistance.

4" DuPont™ Flashing Tape is an alternative to 3" DuPont™ Tyvek® Tape where specified in the *DuPont™ Tyvek® Air and Water Barrier Installation Guidelines for Buildings Greater Than 4 Stories*.

## DuPont Self-Adhered Flashing Systems Installation Guidelines

Door and window rough sill framing must be level or slightly sloped to the exterior to ensure proper drainage to the exterior.

DuPont™ Window & Door Foam can be used in lieu of sealant to create a continuous seal around the interior perimeter of the window openings. Refer to the DuPont™ Window & Door Foam FAQ posted on [www.weatherization.tyvek.com](http://www.weatherization.tyvek.com) for additional usage information.

**DO NOT STRETCH** DuPont™ FlexWrap™ NF when installing along sills or jambs. DuPont™ FlexWrap™ NF is only intended to be stretched when covering corners or curved sections.

DuPont™ self-adhered flashing products perform best when installed at temperatures above 25°F (-4°C).

Avoid placing DuPont™ Tyvek® Wrap Cap Fasteners where flashing will be installed; however, DuPont™ Tyvek® Wrap Cap Fasteners can be applied over the flashing.

For extreme/coastal exposures installation of a high pressure skirt is recommended to help prevent water intrusion at the sill or threshold.

For high pressure design loads, the use of DuPont™ StraightFlash™ with wrap cap screws is required to secure the head flap of the windows.

Adverse weather conditions or cold temperatures may require use of a primer to promote adhesion of DuPont™ self-adhered flashing products to most common building materials. Concrete, masonry, and fiber-faced exterior gypsum board require the use of DuPont™ Adhesive/Primer.

### **For window or door openings greater than 6 feet wide (commercial installations only):**

A 3-piece sill and head detail is allowed using DuPont™ StraightFlash™ and DuPont™ FlexWrap™ NF corners. DuPont™ StraightFlash™ should be applied the length of the sill prior to placing the FlexWrap™ NF corners. The FlexWrap™ NF corners should be at least 12" long allowing for 6" up the jamb and 6" of overlap on the StraightFlash™ sill flashing. When applying the 3-piece flashing detail to the head of the opening, the StraightFlash™ head piece should be applied prior to installing the FlexWrap™ NF corner flashing. Minimum overlapping of the StraightFlash™ head flashing and jamb flashing should be a minimum of 6".

Packaged Terminal Air Conditioners (PTAC) units should be flashed in accordance with non-flanged window details (pages 7-14) or with DuPont™ StraightFlash™ VF pursuant to the detail for brick mold windows (page 26-33).

Additional CAD technical drawings are available at [www.weatherization.tyvek.com](http://www.weatherization.tyvek.com).

Please call 1-800-44-Tyvek (800-448-9835), visit [www.weatherization.tyvek.com](http://www.weatherization.tyvek.com), or consult your local DuPont™ Tyvek® Specialist for additional information and installation support.

## **Key Installation Requirements for Drainable Window / Door Installation Under the Limited Product and Labor Warranty**

When flashing windows or doors, the following principles must be followed:

- When installed properly, DuPont™ StraightFlash™, DuPont™ StraightFlash™ VF, DuPont™ FlexWrap™ NF, and DuPont™ Flashing Tape provide nail sealability at window/door openings to help protect critical window-wall interfaces. Metal sill pan flashing may be used, but must not replace flexible sill flashing that provides nail sealability.
- DuPont™ self-adhered flashing systems products comply with AAMA 711-13, *Voluntary Specification for Self Adhering Flashing Used for Installation of Exterior Wall Fenestration Products*, which has a modified version of ASTM D 1970 and it is more representative for vertical wall applications.
- Ensure that sill flashing does not slope to the interior. An exterior slope is recommended, but not required.
- Direct water onto an acceptable air and water barrier drainage plane with an unobstructed path to the exterior of the wall. Provide a drainage path for any water intrusion through the window/door attachment system that collects at the sill.
- Properly integrate flashing with acceptable DuPont™ Tyvek® air and water barrier in accordance with the instructional drawing. Self-adhered flashing must be applied with a minimum 2" lap onto the air and water barrier.
- Review the sealant manufacturer's literature or label to confirm that the products used have the chemical and adhesive properties necessary for use with the DuPont flashing materials. Refer to *Chemical Compatibility of Representative Building Sealants* (K-27282) for more information about chemical compatibility.



## DuPont Self-Adhered Flashing Systems Installation Guidelines

- DuPont requires that DuPont™ FlexWrap™ EZ, FlexWrap™ NF, StraightFlash™, and StraightFlash™ VF be covered within nine months (270 days) of installation. DuPont requires that DuPont™ Flashing Tape be covered within four months (120 days) of installation.
- Ensure the sealant materials meet the installation temperature requirements of the sealant manufacturer.
- Properly prepare all surfaces (remove dirt, dust, or moisture, etc.) per manufacturer's recommendations.
- Barrier installations (full perimeter seal on exterior) are acceptable only in the following instances:
  - Slab on grade doors, store front windows, or other systems with built-in drainage mechanisms that have potential for exposure to standing water
  - Surface barrier wall systems with non-water sensitive framing material (i.e., CMU walls)
  - Very low wind / rain exposure regions (southwest / desert) that follow AAMA 2400 installation guideline
- Ensure that window / door and flashing system design takes into account common factors that will impact performance, such as:
  - Climate considerations: Rainfall, Wind, Temperature (hot / cold cycles), Humidity
  - Building design: Window / Wall Design (overhangs, recessed openings, bump-outs), Wall Assembly (wood frame or masonry), Window System (wood or vinyl), New Construction or Replacement Window drainage path
  - UV exposure prior to the construction of the exterior facade
  - Compliance with fire resistance code requirements. For more information about NFPA 285 compliant wall assemblies utilizing DuPont™ Tyvek® Air and Water Barrier products visit [www.weatherization.tyvek.com](http://www.weatherization.tyvek.com)
- Field testing the window / door and wall installation as a complete system is a recommended best practice.
- Use of trained installers is highly recommended.

### Installation Methods for DuPont Flashing Systems products AFTER DuPont™ Tyvek® Air and Water Barrier is Installed

#### Non-Flanged Window

Method applies to following products:

- DuPont™ StraightFlash™
- DuPont™ FlexWrap™ NF

#### STEP 1

A. Cut rough opening in sheathing for window. Ensure that sheathing is cut flush with, or slightly below the sill framing to allow for positive drainage.

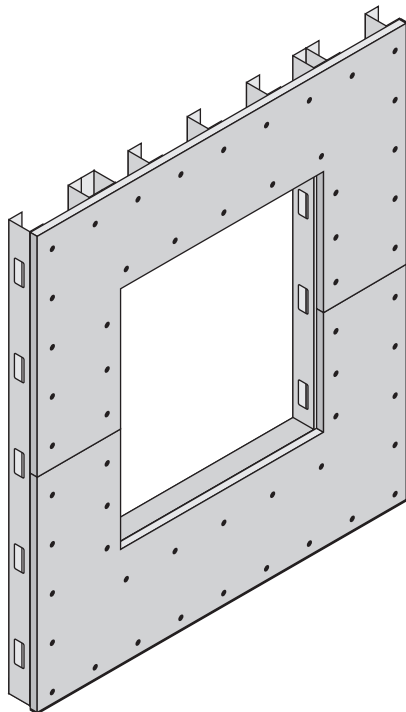

#### STEP 2

A. Wrap wall as shown in *DuPont™ Tyvek® Mechanically Fastened Air and Water Barrier Installation Guidelines for Buildings Greater Than 4 Stories* that can be found at [www.weatherization.tyvek.com](http://www.weatherization.tyvek.com). Do not install fasteners within 6" of the sills and jambs of the openings and within 9" of the head of the openings.

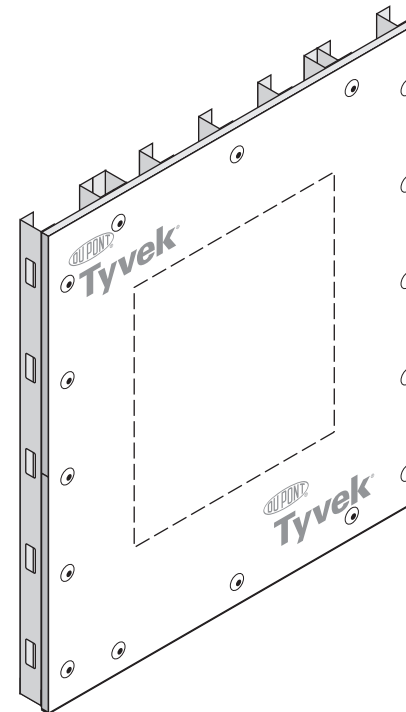

## DuPont Self-Adhered Flashing Systems Installation Guidelines

### STEP 3

Prepare air and water barrier for window installation.

- Cut an opening in the DuPont™ Tyvek® air and water barrier using a square cut around the perimeter of the rough opening.
- Cuts should be made along the dashed indicated lines. (Ensure that the DuPont™ Tyvek® air and water barrier is cut flush with the sheathing and is not wrapped into the rough opening.)
- Cut a head flap at a 45° angle to expose 8" of sheathing to allow for head flashing installation.

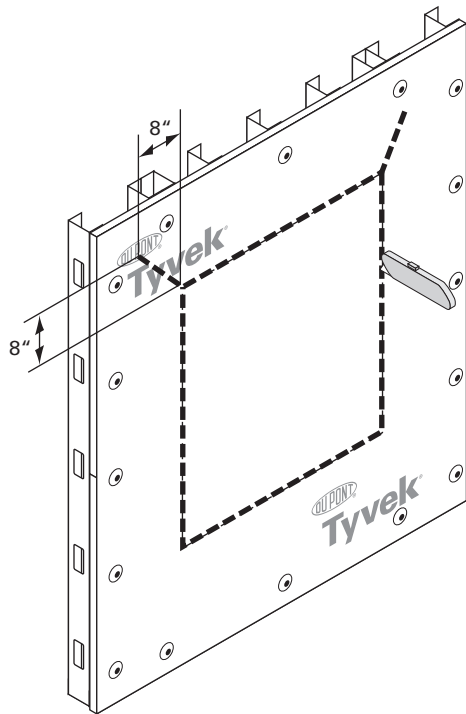

### STEP 4

- Flip the head flap up to expose the sheathing and temporarily secure flap with tape.
- Temporarily secure DuPont™ Tyvek® air and water barrier with DuPont™ Tyvek® Tape around rough opening before flashing is installed to help facilitate flashing installation.

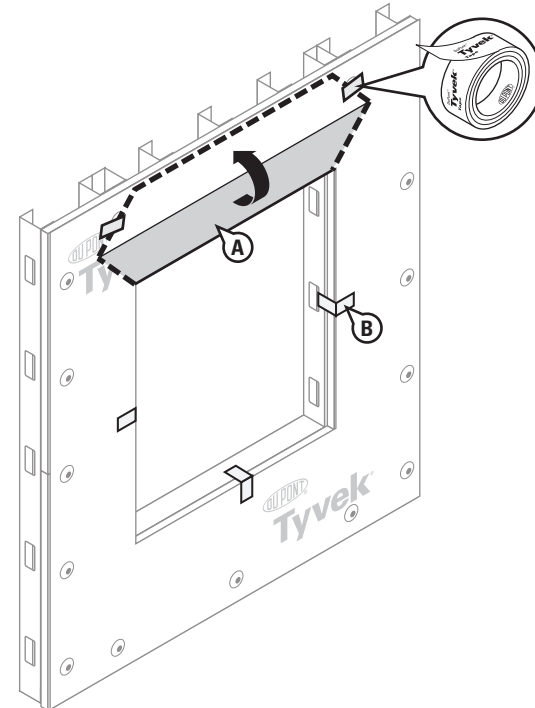

## DuPont Self-Adhered Flashing Systems Installation Guidelines

### STEP 5

- A. Prepare the sill flashing by cutting a piece of DuPont™ FlexWrap™ NF that is at least 12" longer than sill length. Use 6" DuPont™ FlexWrap™ NF for 2" x 4" framing and 9" DuPont™ FlexWrap™ NF for 2" x 6" framing.
- B. Inspect installation surface to ensure surface is free of dirt or substances that could interfere with adhesion as well as any sharp protrusions.

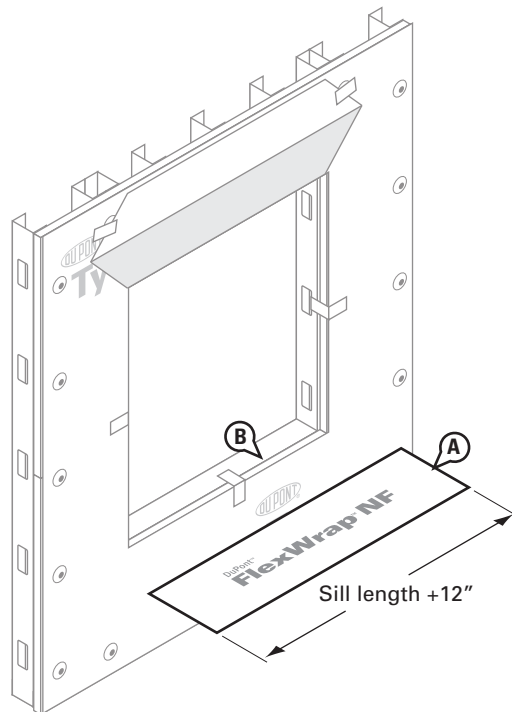

### STEP 6

- A. Install the sill flashing. Remove the largest strip of release paper, align the flashing with the interior edge of sill, and install into rough opening across sill and up jambs (min 6"). Apply working from the middle of the sill towards the sides. Secure DuPont™ FlexWrap™ NF tightly into the corners by first working in along the sill before adhering up the jambs.
- B. Cover holes in studs with patches of DuPont™ StraightFlash™.

**DO NOT STRETCH MATERIAL ALONG THE SILL OR JAMBS.**

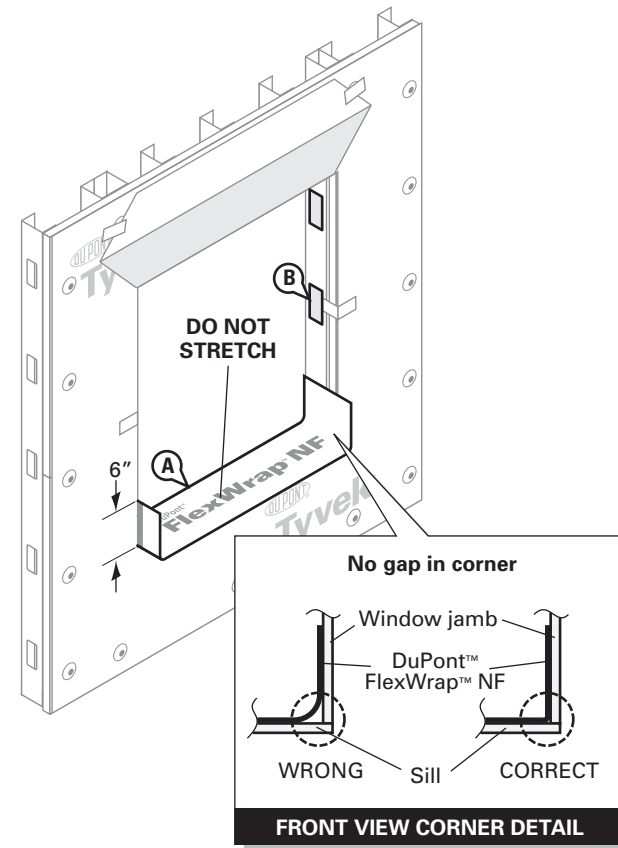

## DuPont Self-Adhered Flashing Systems Installation Guidelines

### STEP 7

- A. Remove second half of the release paper.
- B. Fan DuPont™ FlexWrap™ NF at bottom corners and adhere onto face of wall.
- C. Firmly press sill flashing to ensure full adhesion on all surfaces. Eliminate wrinkles and bubbles by smoothing surface and repositioning as necessary.

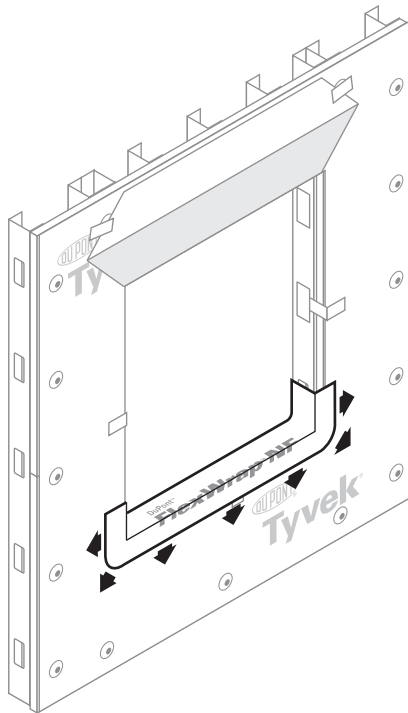

### STEP 8

- A. Cut the jamb flashing the vertical length of the rough opening. Jamb flashing should be long enough to overlap the sill flashing by at least 2" and be overlapped by future head flashing by at least 2".
- B. Wrap 9" DuPont™ StraightFlash™ into the rough opening at each jamb and onto wall face. The flashing should align with the interior edge of the jamb framing.

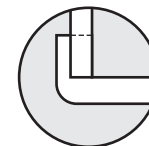
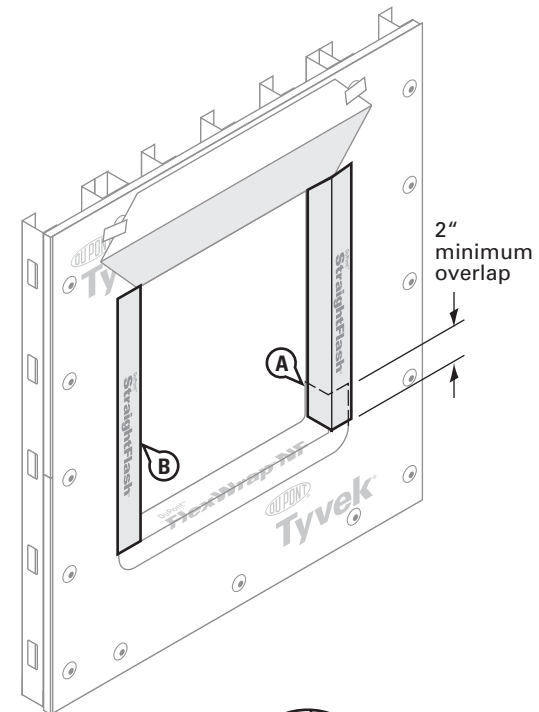

**INCORRECT**  
DuPont™ FlexWrap™ NF  
reverse flashed

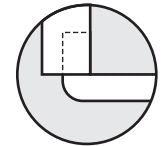

**CORRECT**  
DuPont™ StraightFlash™  
overlaps DuPont™  
FlexWrap™ NF



## DuPont Self-Adhered Flashing Systems Installation Guidelines

### STEP 9

A. Apply DuPont™ Adhesive/Primer to the top of the jambs and exposed sheathing.

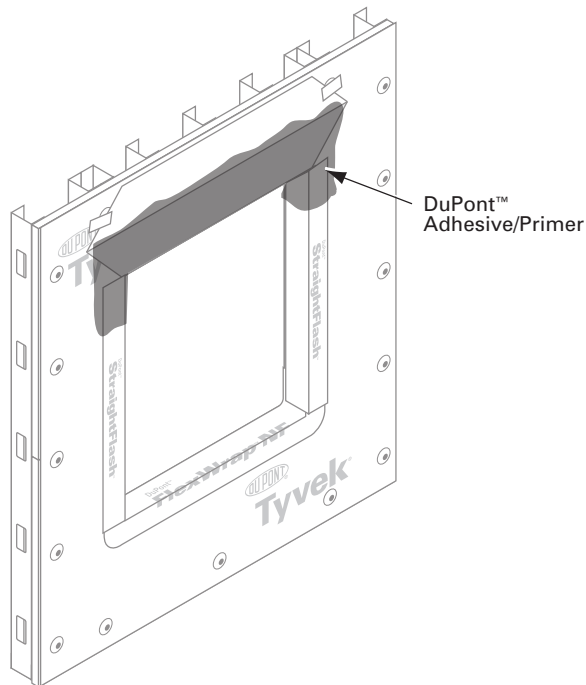

### STEP 10

A. Adhere DuPont™ FlexWrap™ NF to the head using the same installation process as shown in steps 6 and 7 for the sill flashing. Make sure the DuPont™ FlexWrap™ NF is cut long enough to overlap the jamb flashing by at least 2”.

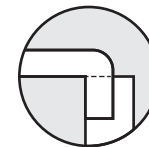
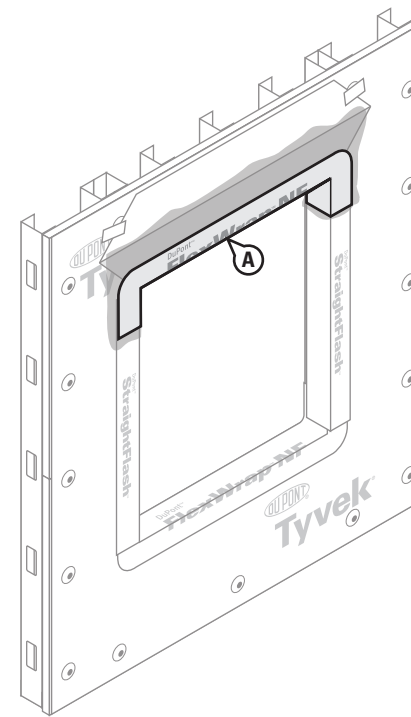

**INCORRECT**  
DuPont™ FlexWrap™ NF  
reverse flashed

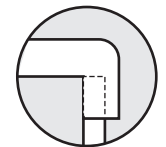

**CORRECT**  
DuPont™ StraightFlash™  
overlaps DuPont™  
FlexWrap™ NF

## DuPont Self-Adhered Flashing Systems Installation Guidelines

### STEP 11

A. If angled caulk stops are used to contain perimeter sealant, they should be attached to window along side jambs and head prior to installation.

The sill will be left open prior to window installation to allow for drainage of incidental moisture.

B. Install window per manufacturer's installation instructions. Apply an exterior perimeter seal using backer rod and sealant along the jambs and head of the window opening. If sealant is applied to the sill, ensure that there are at least two (2) 2" gaps in the sealant bead for every 4' of window to allow for drainage.

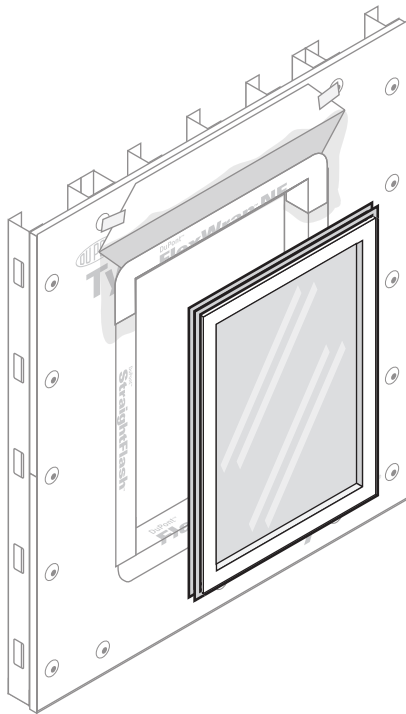

### STEP 12

A. As a best practice for high exposure areas, install metal drip cap above the head joint when specified.

B. Apply a strip of 4" DuPont™ StraightFlash™ over the drip cap.

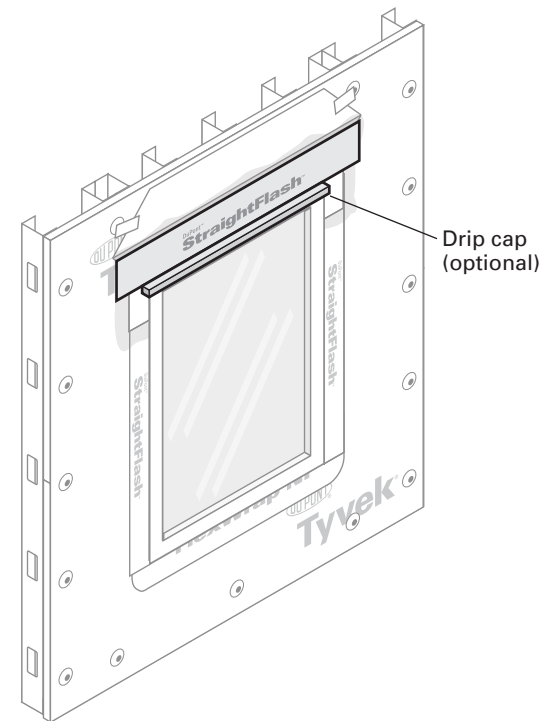

## DuPont Self-Adhered Flashing Systems Installation Guidelines

### STEP 13

- A. Flip down the head flap and **trim 1"-2" above the window opening**. Terminate flap along the top of the window with 3" DuPont™ Tyvek® Tape or 4" DuPont™ StraightFlash™. (See General Instructions for when 3" DuPont™ Tyvek® Tape is allowed).
- B. Apply 4" DuPont™ StraightFlash™ over the diagonal seams.
- C. For high performance designs or areas of extreme exposure use 4" DuPont™ StraightFlash™ to seal the head flap and install additional mechanical fasteners through the flashing at the head flap and perimeter of window.

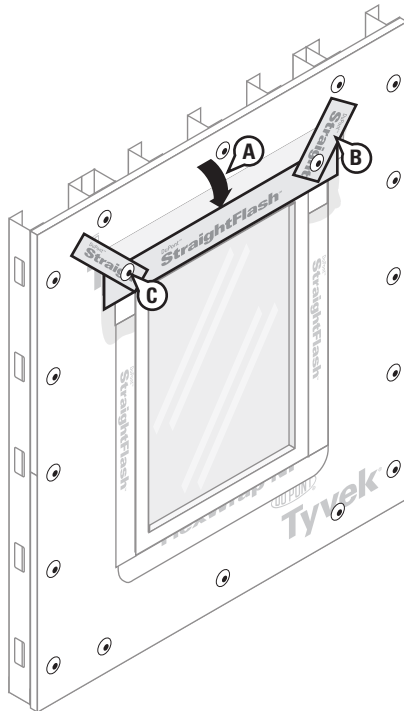

### STEP 14

#### Interior View

- A. Create a continuous perimeter seal using backer rod and sealant or DuPont™ Window and Door Foam on window interior to resist air and water infiltration.

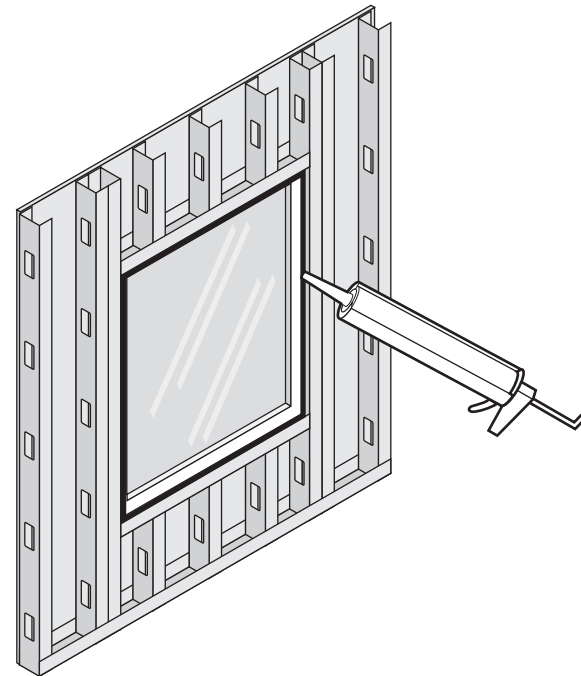

## DuPont Self-Adhered Flashing Systems Installation Guidelines

### STEP 14-A (OPTIONAL ALTERNATE BACK DAM PART 1)

A. While the sealant is still wet, as a best practice, install an “L” shaped back dam cut the width of the rough opening so that it contacts the sealant bead and rear of window. Apply sealant along four sides of the exposed back dam. **OPTIONAL:** Apply sealant along all four sides in lieu of back dam. **NOTE:** For alternate back dam see the Brick Mold Installation Guide, Steps 2 and 7, later in this document.

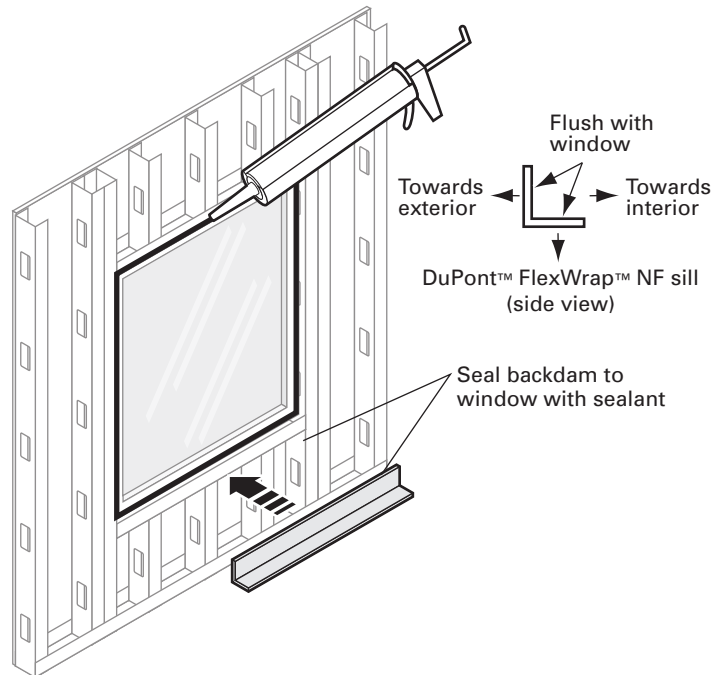

### STEP 14-B (OPTIONAL ALTERNATE BACK DAM PART 2)

A. Install retention clips around the window to permanently secure it in the rough opening as recommended by window manufacturer to complete installation.

B. When the facade is complete, place a continuous sealant bead integrating the window to the facade.

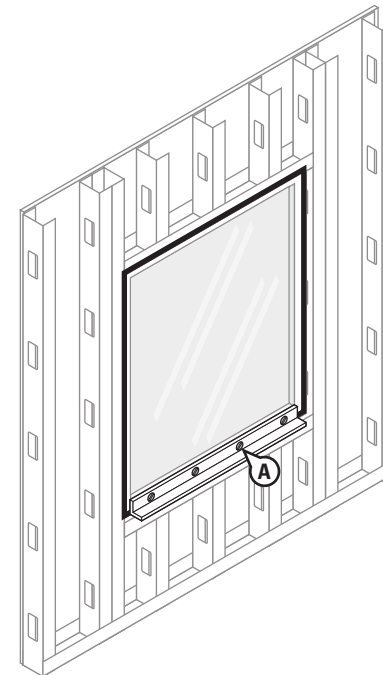

## DuPont Self-Adhered Flashing Systems Installation Guidelines

### Non-Flanged Window with Lintel and Brick Facade

Method applies to following products:

- DuPont™ StraightFlash™
- DuPont™ FlexWrap™ NF

#### STEP 1

A. Cut rough opening in sheathing for window. Ensure that sheathing is cut flush with, or slightly below the sill framing to allow for positive drainage.

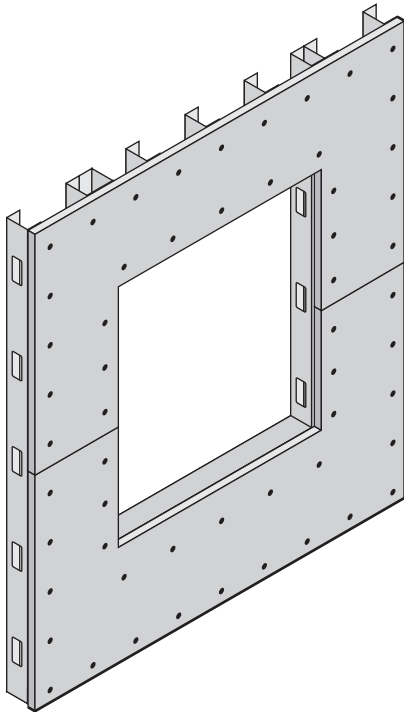

#### STEP 2

A. Wrap wall as shown in *DuPont™ Tyvek® Mechanically Fastened Air and Water Barrier Installation Guidelines for Buildings Greater Than 4 Stories* that can be found at [www.weatherization.tyvek.com](http://www.weatherization.tyvek.com). Do not install fasteners within 6" of the sills and jambs of the openings and within 9" of the head of the openings.

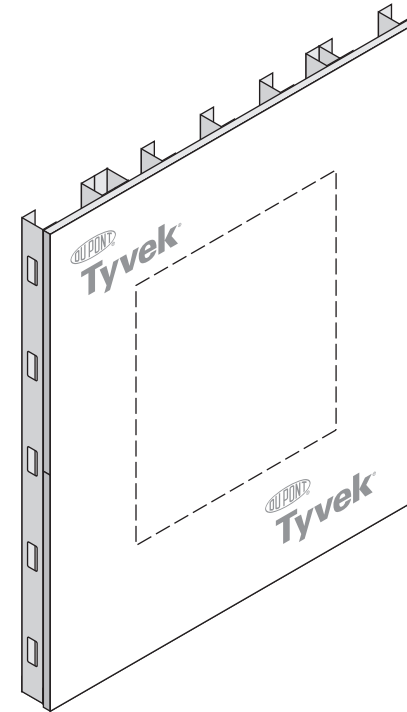



## DuPont Self-Adhered Flashing Systems Installation Guidelines

### STEP 3

- Cut an opening in the DuPont™ Tyvek® air and water barrier using a full cut out around the perimeter of the opening.
- Temporarily secure DuPont™ Tyvek® air and water barrier with DuPont™ Tyvek® Tape around rough opening before flashing is installed to help facilitate flashing installation.
- Prepare the sill flashing by cutting a piece of DuPont™ FlexWrap™ NF that is at least 12" longer than sill length. Use 6" DuPont™ FlexWrap™ NF for 2" x 4" framing and 9" FlexWrap™ NF for 2" x 6" framing.
- Inspect installation surface to ensure surface is free of dirt or substances that could interfere with adhesion as well as any sharp protrusions.

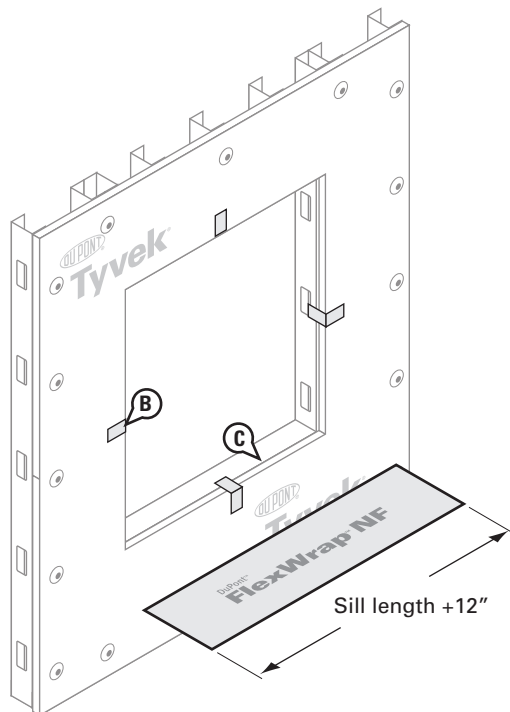

### STEP 4

- Install the sill flashing. Remove the largest strip of release paper, align the flashing with the interior edge of sill, and install into rough opening across sill and up jambs (min 6"). Apply working from the middle of the sill towards the sides. Secure DuPont™ FlexWrap™ NF tightly into the corners by first working in along the sill before adhering up the jambs.

**DO NOT STRETCH MATERIAL ALONG THE SILL OR JAMBS.**

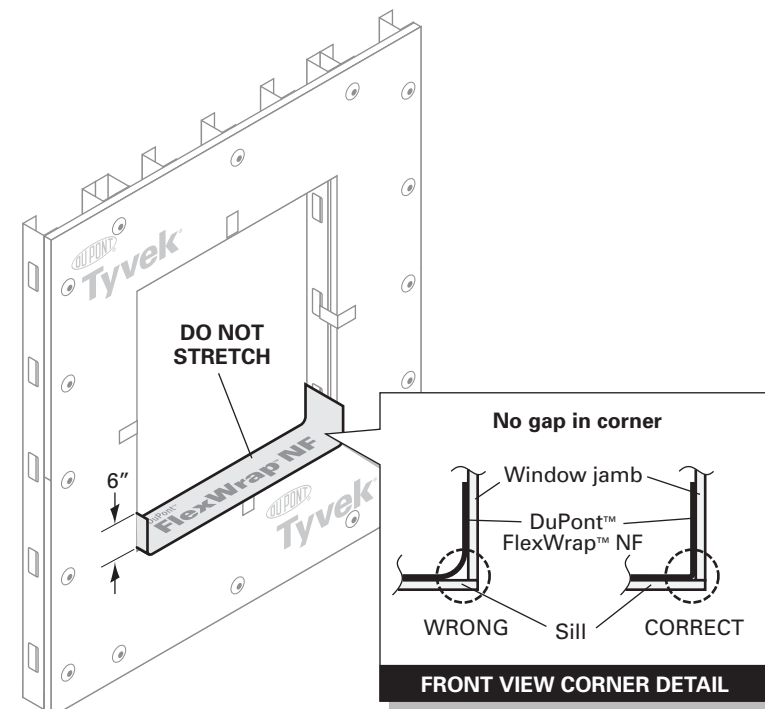

## DuPont Self-Adhered Flashing Systems Installation Guidelines

### STEP 5

- Remove second half of the release paper.
- Fan DuPont™ FlexWrap™ NF at bottom corners and adhere onto face of wall.
- Firmly press sill flashing to ensure full adhesion on all surfaces. Eliminate wrinkles and bubbles by smoothing surface.

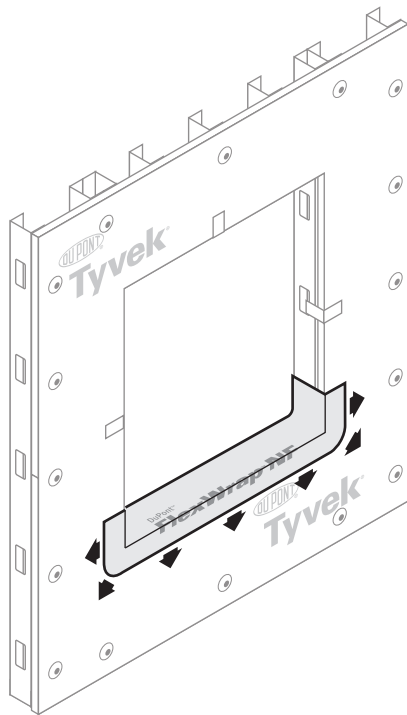

### STEP 6

- Cut the jamb flashing the vertical length of the rough opening. Jamb flashing should be long enough to overlap the sill flashing by at least 2" and be overlapped by future head flashing by at least 2".
- Wrap 9" DuPont™ StraightFlash™ into the rough opening at each jamb and onto wall face. The flashing should align with the interior edge of the jamb framing.

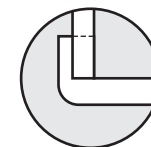
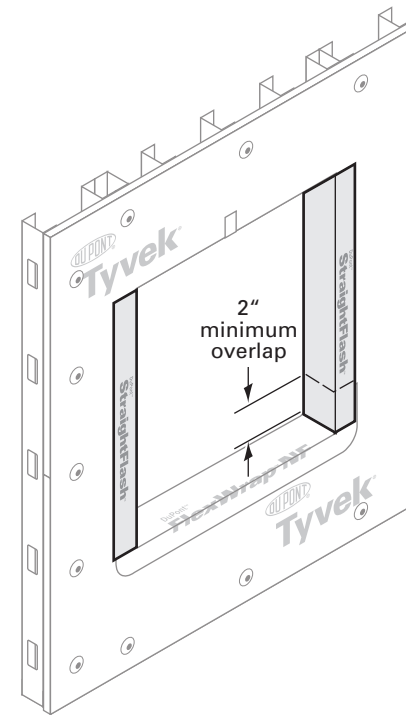

**INCORRECT**  
DuPont™ FlexWrap™ NF  
reverse flashed

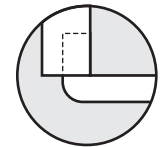

**CORRECT**  
DuPont™ StraightFlash™  
overlaps DuPont™  
FlexWrap™ NF

## DuPont Self-Adhered Flashing Systems Installation Guidelines

### STEP 7

- A. Adhere DuPont™ FlexWrap™ NF to the head using the same installation process as shown in steps 4 and 5 for the sill flashing. Make sure the DuPont™ FlexWrap™ NF is cut long enough to overlap the jamb flashing by at least 2 inches.
- B. **OPTIONAL:** For some facades, and when specified by the architect, exterior insulation should be added at this time. DuPont™ Tyvek® CommercialWrap® D is specially engineered to provide an enhanced drainage plane and is recommended in these situations.

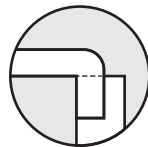
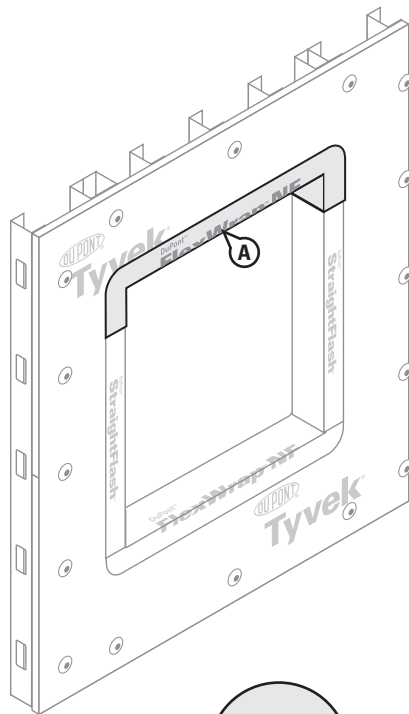

**INCORRECT**  
DuPont™ FlexWrap™ NF  
reverse flashed

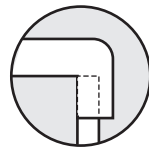

**CORRECT**  
DuPont™ StraightFlash™  
overlaps DuPont™  
FlexWrap™ NF

### STEP 8

- A. Cut flap in the DuPont™ Tyvek® air and water barrier.
- B. Apply DuPont™ Adhesive/Primer to exposed sheathing.
- C. Install lintel on masonry as required.

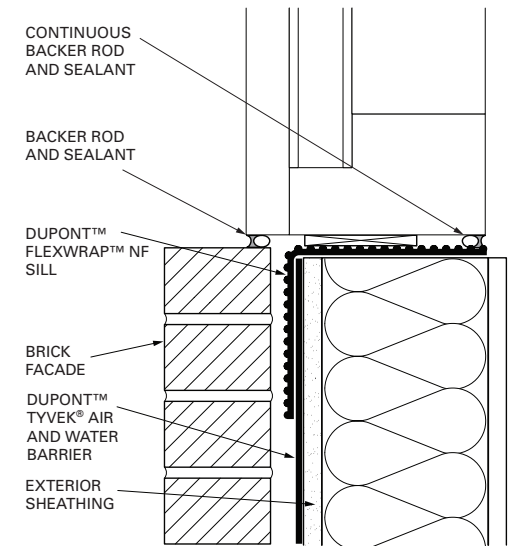
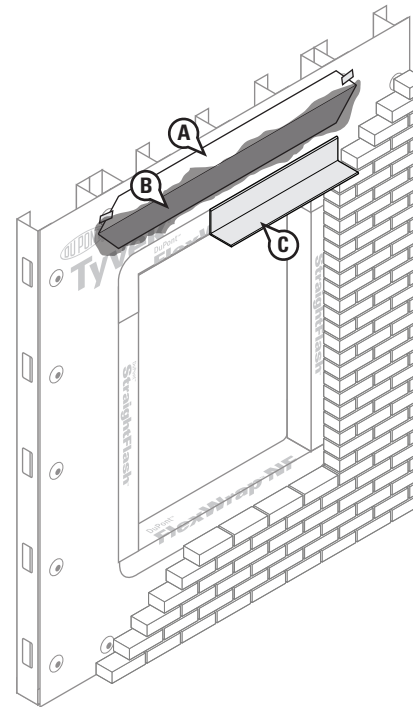

## DuPont Self-Adhered Flashing Systems Installation Guidelines

### STEP 9 Head Detail Using Metal Pan Flashing

- A. Install corrosion-resistant metal pan with drip and soldered/sealed end dams above lintel. Extend flashing beyond the end of lintel.
- B. Install 9" wide strip of DuPont™ StraightFlash™ to bridge between the exterior sheathing and the metal pan flashing. Maintain a minimum of 3" contact between the DuPont™ StraightFlash™ and the primed exposed sheathing surface.
- C. Cut a vertical slit in the DuPont™ StraightFlash™ to accommodate the vertical edge of the metal pan.
- D. Install an additional layer of either 4" or 9" DuPont™ StraightFlash™ over the first layer of DuPont™ StraightFlash™ if necessary to achieve the 3" minimum contact to the exposed exterior sheathing. The overlap should be a minimum of 1".

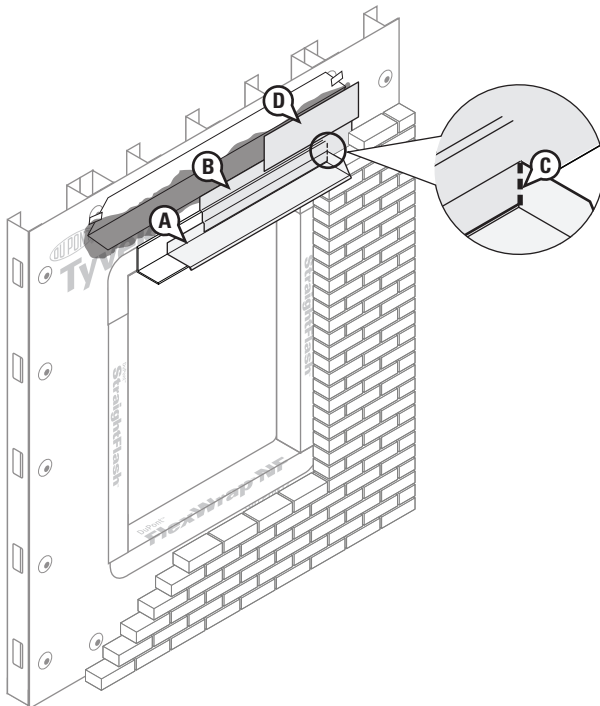

### STEP 9 (ALTERNATE) Head Detail Using Through Wall Flashing

- A. Embed through wall flashing end dams in sealant and install along outer edge of lintel.
- B. Install through wall flashing with a minimum of 3" adhering to the wall sheathing, then overlapping the lintel. Extend the through wall flashing a minimum of 1/4" beyond the outside edge of the lintel to form a drip edge.
- C. Apply sealant along the edges of the through wall flashing.

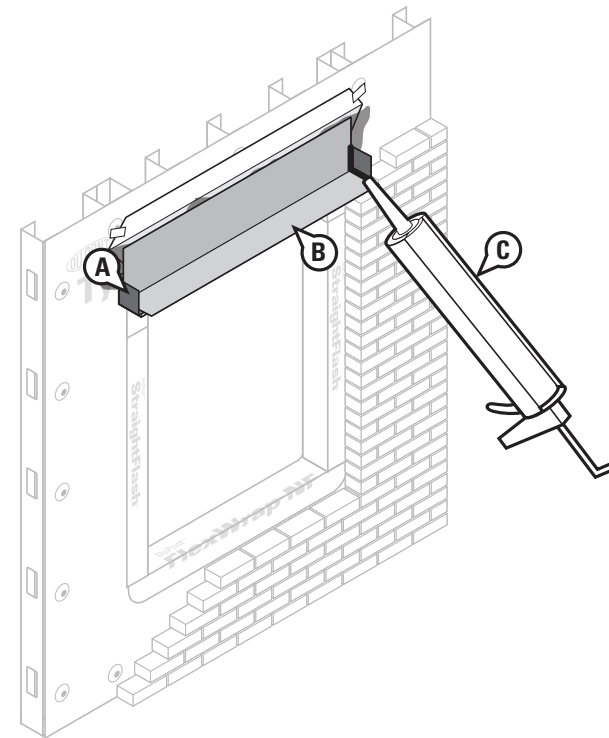

## DuPont Self-Adhered Flashing Systems Installation Guidelines

### STEP 10

- A. Fold head flap back into place.
- B. Tape along bottom edge of cut in DuPont™ Tyvek® air and water barrier with DuPont™ StraightFlash™.
- C. Use 4" wide DuPont™ StraightFlash™ at diagonal cut in DuPont™ Tyvek® air and water barrier to secure head flap.

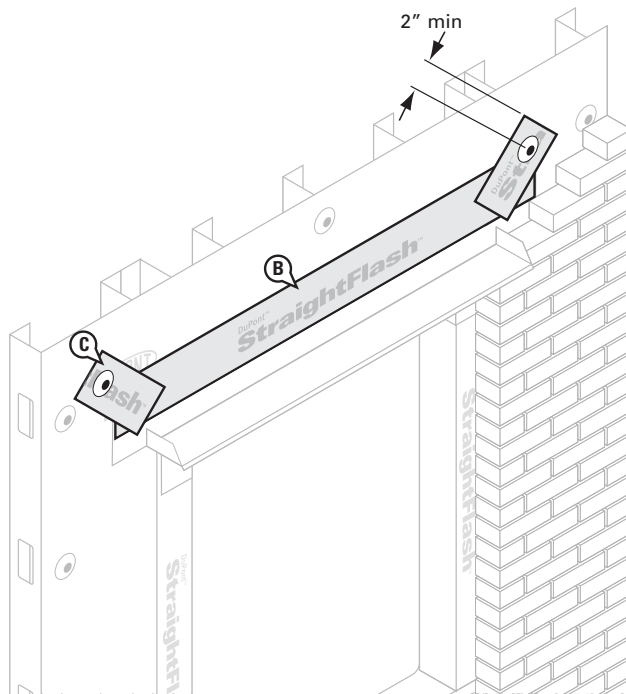

### STEP 11

- A. Anchor the non-corrosive metal sill pan flashing to the wall and integrate to the DuPont™ Tyvek® air and water barrier with 4" DuPont™ StraightFlash™.

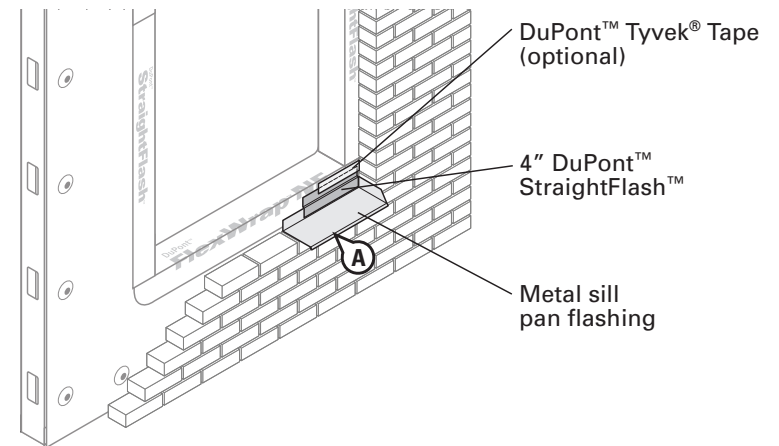



## DuPont Self-Adhered Flashing Systems Installation Guidelines

### STEP 12

- A. Install remaining masonry with weeps along flashing.
- B. Install window per manufacturer's instructions.
- C. Seal all four sides of the perimeter of the window.

**DO NOT SEAL ANY WEEPS OF WINDOW FRAME.**

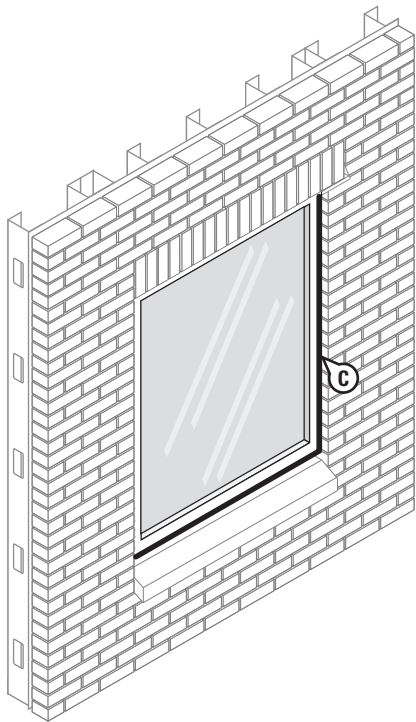

## DuPont Self-Adhered Flashing Systems Installation Guidelines

### STEP 13

#### Interior View

A. Create a continuous perimeter seal using backer rod and sealant or DuPont™ Window and Door Foam rod and sealant on window interior to resist air and water infiltration.

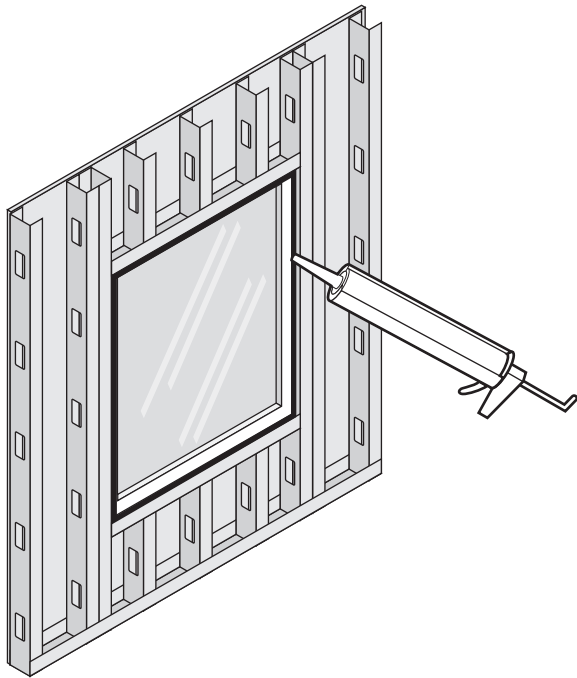

### STEP 13-A (OPTIONAL ALTERNATE BACK DAM PART 1)

A. While the sealant is still wet, as a best practice, install an "L" shaped back dam cut the width of the rough opening so that it contacts the sealant bead and rear of window. Apply sealant along four sides of the exposed back dam. **OPTIONAL:** Apply sealant along all four sides in lieu of back dam. **NOTE:** For alternate back dam see the Brick Mold Installation Guide, steps 2 and 7, later in this document.

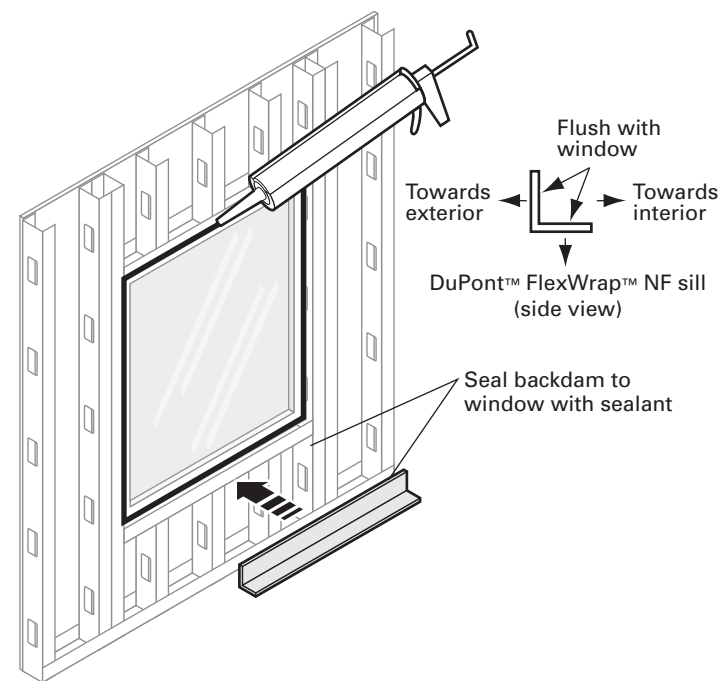

## DuPont Self-Adhered Flashing Systems Installation Guidelines

### STEP 13-B (OPTIONAL ALTERNATE BACK DAM PART 2)

A. Install retention clips around the window to permanently secure it in the rough opening as recommended by window manufacturer to complete installation.

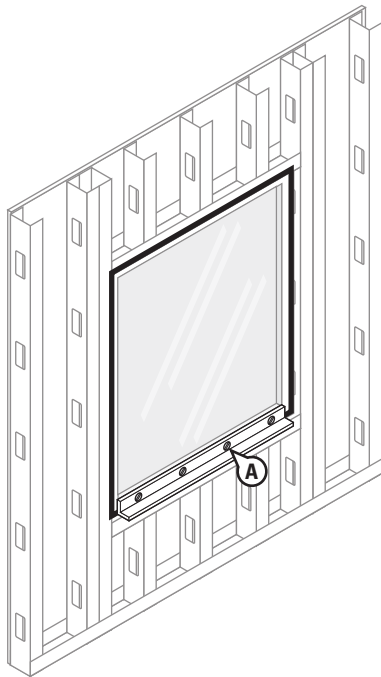

### Optional Jamb Detail (top view)

**NOTE:** For other CAD details visit [www.weatherization.tyvek.com](http://www.weatherization.tyvek.com)

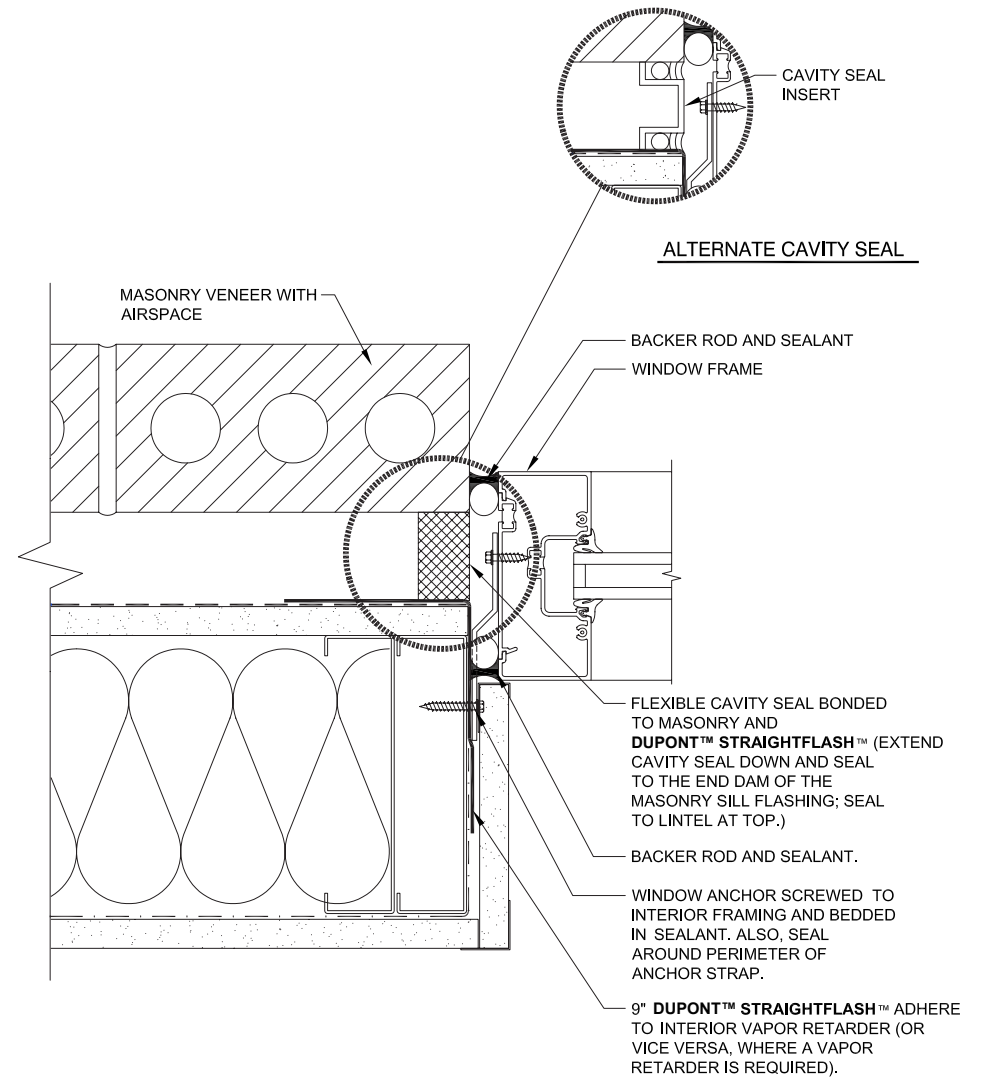

# DuPont Self-Adhered Flashing Systems Installation Guidelines

## Sill Detail (side view) Metal Through Wall Flashing

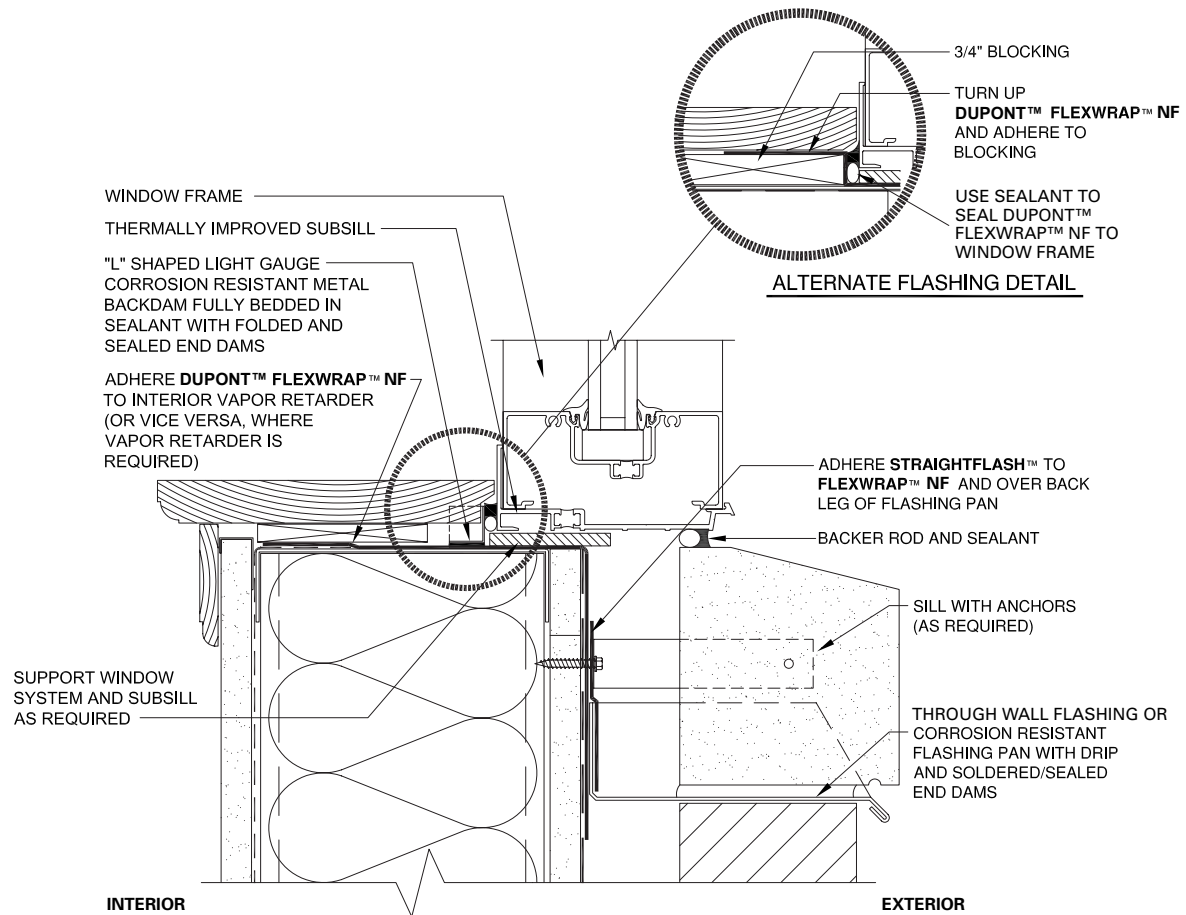

# DuPont Self-Adhered Flashing Systems Installation Guidelines

## ALTERNATE HEAD DETAIL (top view) Floating lintel after window flashing

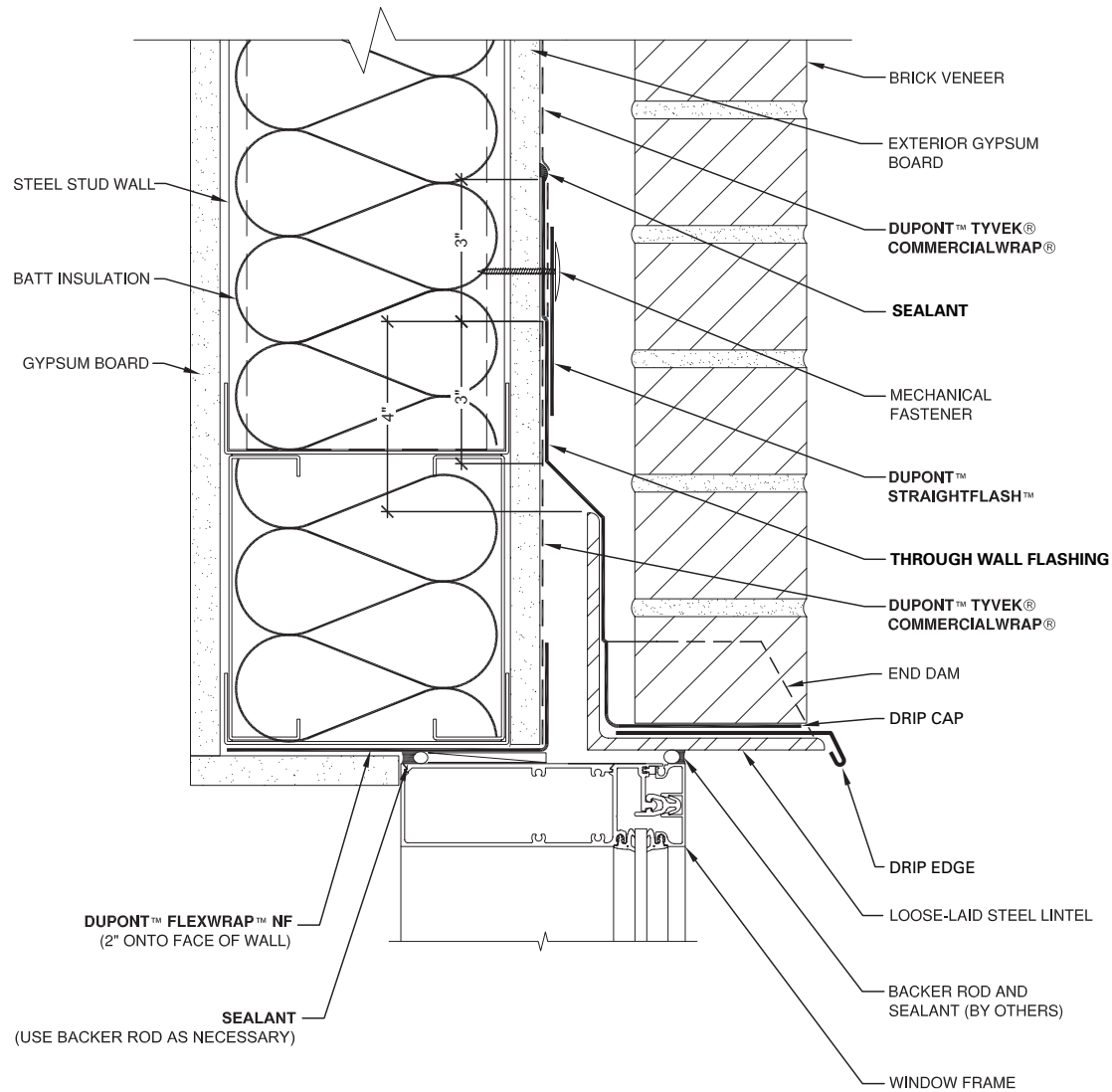



# DuPont Self-Adhered Flashing Systems Installation Guidelines

## Alternate for Lintels attached prior to window flashing

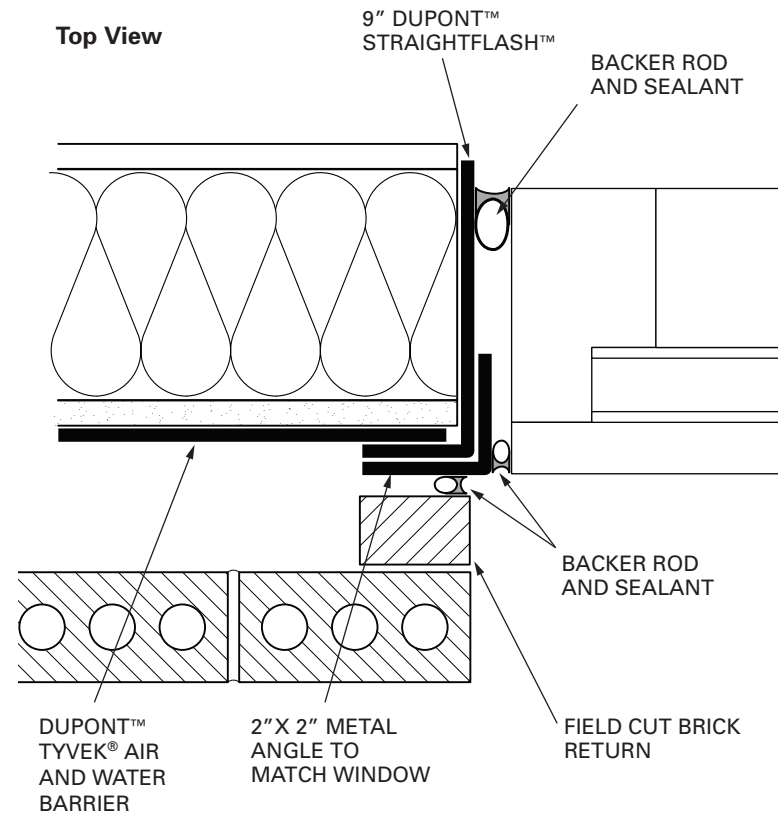
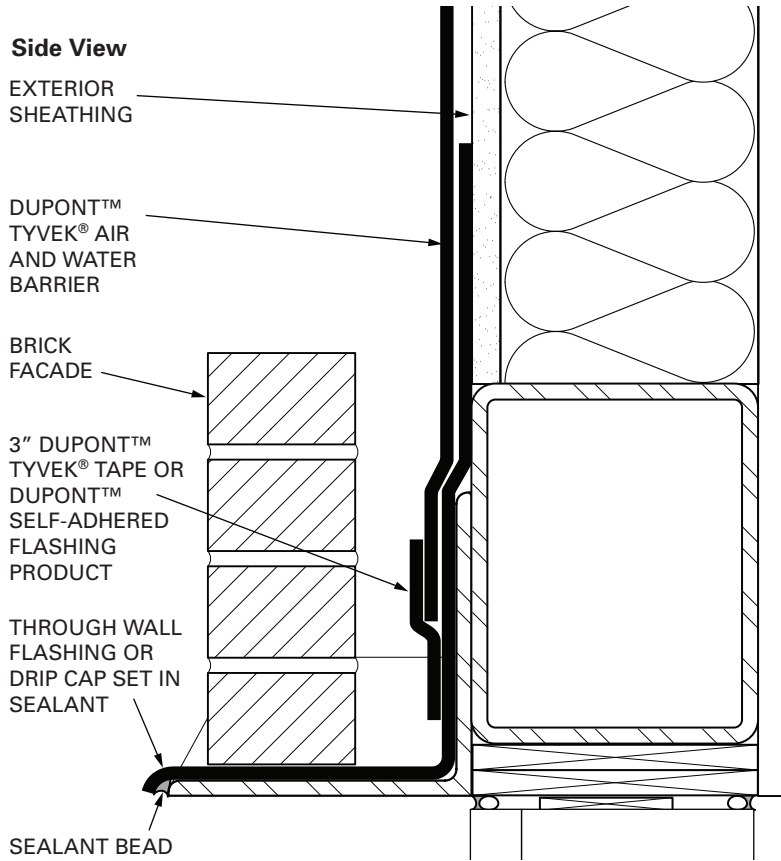

## DuPont Self-Adhered Flashing Systems Installation Guidelines

### Brick Mold Window

This installation guide can also be used for windows with field applied nailing fins.  
Method applies to following products:

- DuPont™ StraightFlash™ VF
- DuPont™ FlexWrap™ NF

### STEP 1

Prepare DuPont™ Tyvek® air and water barrier for window installation:

- Make an "I-Cut" in the DuPont™ Tyvek® air and water barrier (a modified I-Cut is also acceptable). For an "I-Cut" begin with a horizontal cut across the bottom and the top of the window frame (for round top windows, cut from the center cut straight down to the sill).
- Cut two 45° slits a minimum of 8" from the corner of the header to create a flap above the rough opening to expose sheathing or framing members and to allow head flashing installation (see step 5). Flip head flap up and temporarily secure with DuPont™ Tyvek® Tape. Some windows and flashing widths may require longer slits due to window shape.
- Fold side flaps into rough opening, cut excess flaps, and secure.

**NOTE:** Side flaps should cover interior facing framing stud.

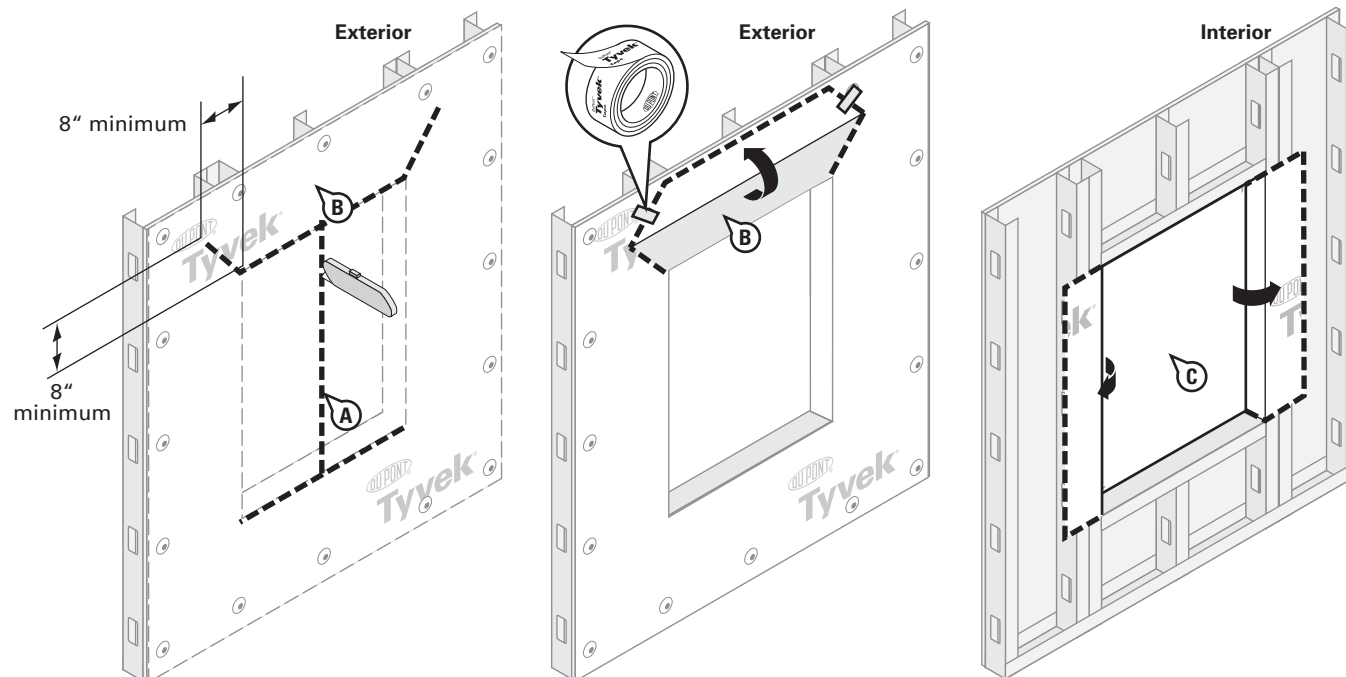

## DuPont Self-Adhered Flashing Systems Installation Guidelines

### STEP 2

- A. Cut DuPont™ FlexWrap™ NF at least 12" longer than width of rough opening sill.
- B. Fold to break perforation. Remove center piece of release paper. Align 6" DuPont™ FlexWrap™ NF with interior edge of sill framing, and adhere into rough opening along sill and up jambs (min 6" on each side).

**OPTIONAL BACK DAM:** Fold 9" DuPont™ FlexWrap™ NF to break perforation. Remove center piece of release paper. Cover horizontal sill leaving 1" of overhang on inside edge of sill for back dam, and adhere into rough opening along sill and up jambs (min 6" on each side). Leave 1" overhang of release paper on DuPont™ FlexWrap™ NF inside rough opening to finish back dam after window installation.

- C. Remove outer release paper.
- D. Flex DuPont™ FlexWrap™ NF at bottom corners onto face of wall.

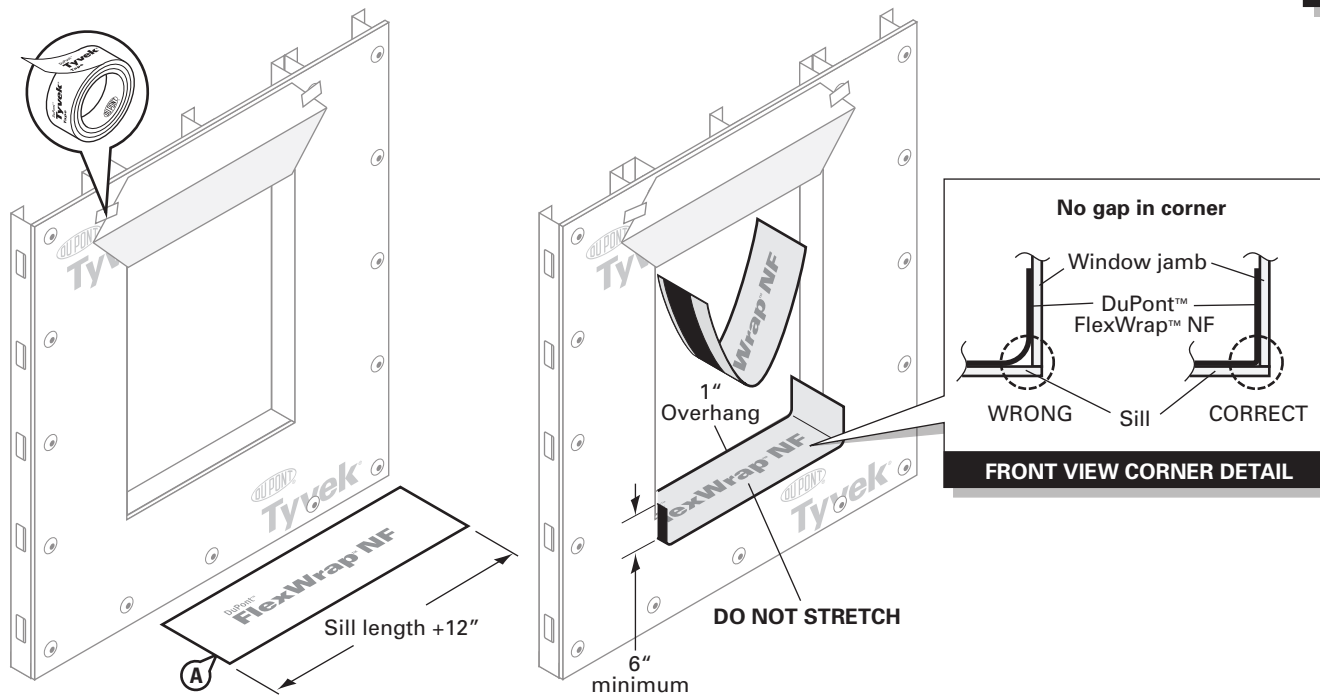
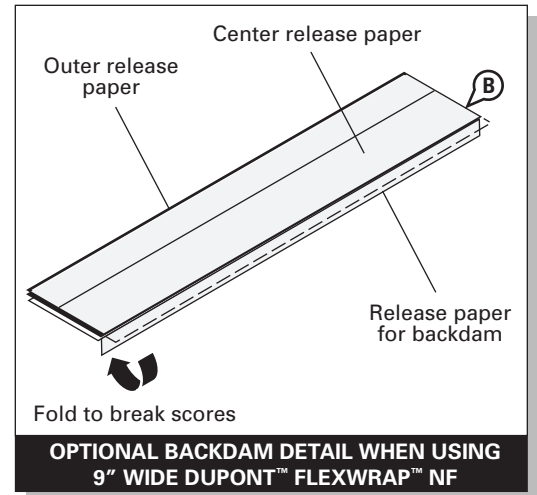

## DuPont Self-Adhered Flashing Systems Installation Guidelines

### STEP 3

- A. Prepare head flashing by cutting a piece of DuPont™ StraightFlash™ VF at least 12" LONGER than the head length.
- B. Break the scored release paper on one side of the head flashing by folding it back and forth upon itself.
- C. Center the flashing on the window head and position so that it contacts the window frame and interior side of the brick mold. Remove the outer release paper and adhere the flashing to the window frame. Use the inner release paper to form a tight seal in the corner where the brick mold attaches to the window frame.
- D. Remove the inner release paper and adhere the flashing to the back of the brick mold and the window casing.
- E. At the corner of the window frame, cut the DuPont™ StraightFlash™ VF along the corner at a 45° angle.
- F. Fold the DuPont™ StraightFlash™ VF down flat against the brick mold.

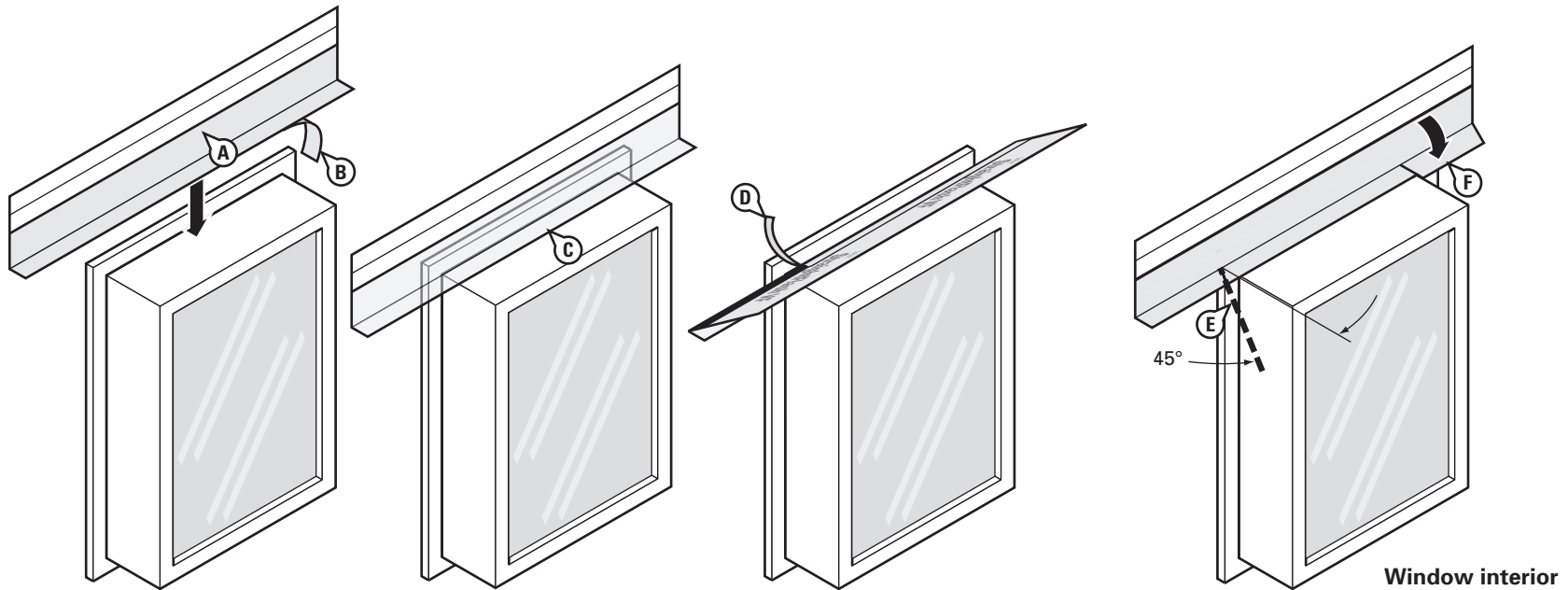
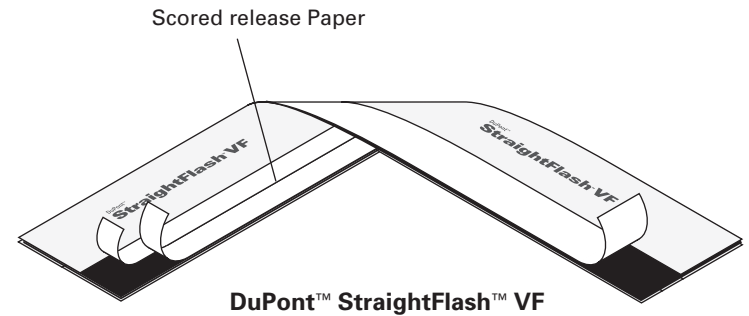

## DuPont Self-Adhered Flashing Systems Installation Guidelines

### STEP 4

- Prepare jamb flashing by cutting a piece of DuPont™ StraightFlash™ VF at least 6" LONGER than the jamb.
- Break the scored release paper on one side of the jamb flashing by folding it back and forth upon itself.
- Position so that it contacts the window frame and interior side of the brick mold. Ensure that the jamb flashing is positioned 1-1/2" below the top edge of the head flashing. Jamb flashing adhesive must come in contact with head flashing adhesive and overlap by 1".

- Remove the outer release paper and adhere the flashing to the window frame. Use the inner release paper to form a tight seal in the corner.
- Remove the inner release paper and adhere the flashing to the back of the brick mold.
- At the corner of the window frame, cut the DuPont™ StraightFlash™ VF along the corner and fold it down flat to adhere against the head flashing.

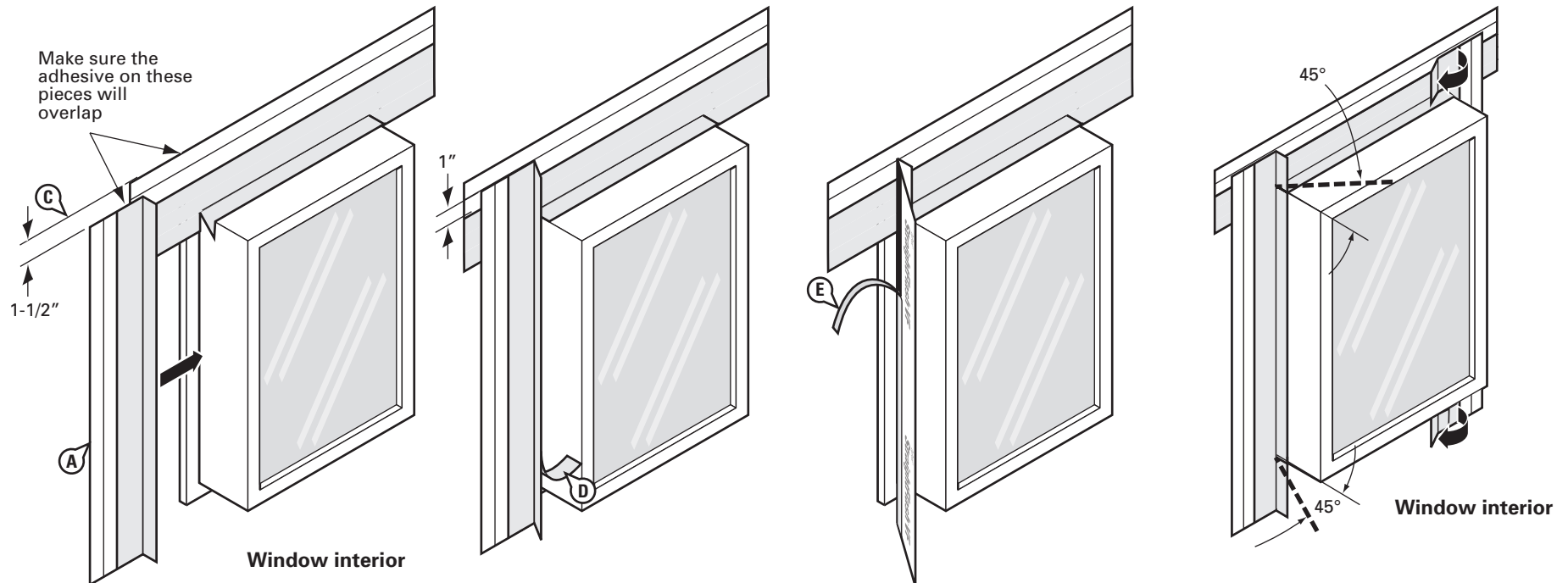

## DuPont Self-Adhered Flashing Systems Installation Guidelines

### STEP 5

- Install window according to manufacturer's installation instructions.
- Apply DuPont™ Adhesive/Primer to exposed sheathing.
- Remove the remaining release paper from the DuPont™ StraightFlash™ VF jamb flashing and press firmly to adhere it to the DuPont™ Tyvek® air and water barrier.
- Remove the release paper at the head and adhere it to the wall surface.
- OPTIONAL:** Cover exposed butyl with DuPont™ StraightFlash™ or DuPont™ Tyvek® Tape.

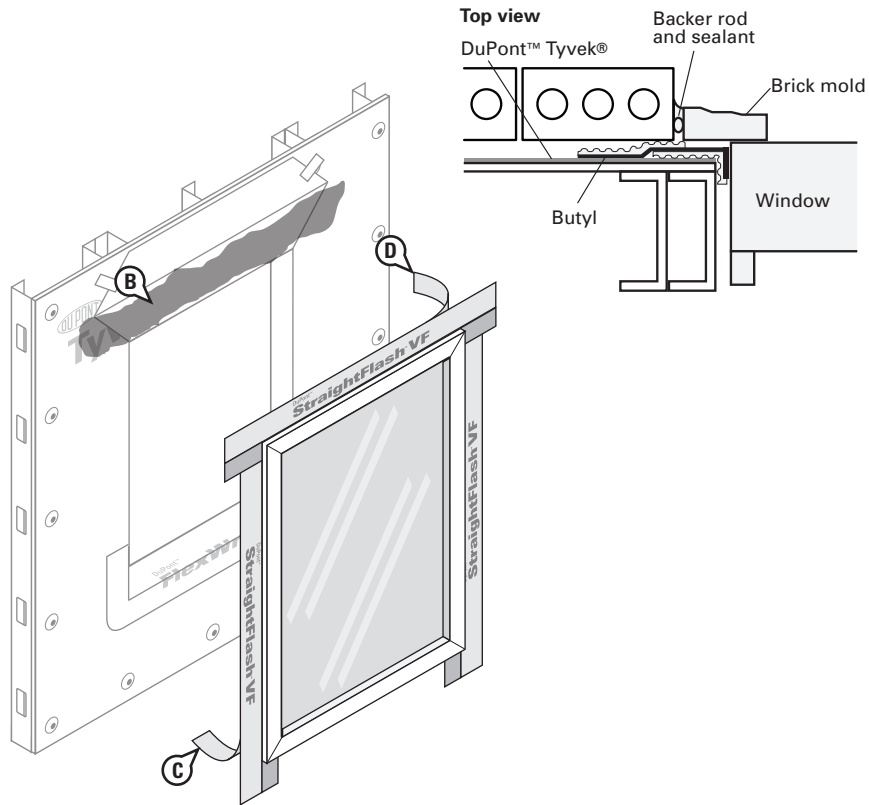

### STEP 6

- Cut a piece of metal or vinyl drip cap slightly longer than the window's width and place a bead of sealant on the rear side. Install the drip cap tight against the window head and cover the top edge with 4" DuPont™ StraightFlash™.
- Flip down upper flap of DuPont™ Tyvek® air and water barrier so it lays flat across head flashing, then **trim 1"-2" above the window opening.**
- Tape along all cuts in DuPont™ Tyvek® air and water barrier and tape across drip cap with 3" DuPont™ Tyvek® Tape or 4" DuPont™ StraightFlash™. (See General Instructions for when 3" DuPont™ Tyvek® Tape is allowed.)
- Install DuPont™ Tyvek® Wrap Cap Fasteners over flashing at recommended spacing.

**NOTE:** For high performance designs or areas of extreme exposure use 4" DuPont™ StraightFlash™ to seal the head flap and install additional mechanical fasteners through the flashing at the head flap and perimeter of window.

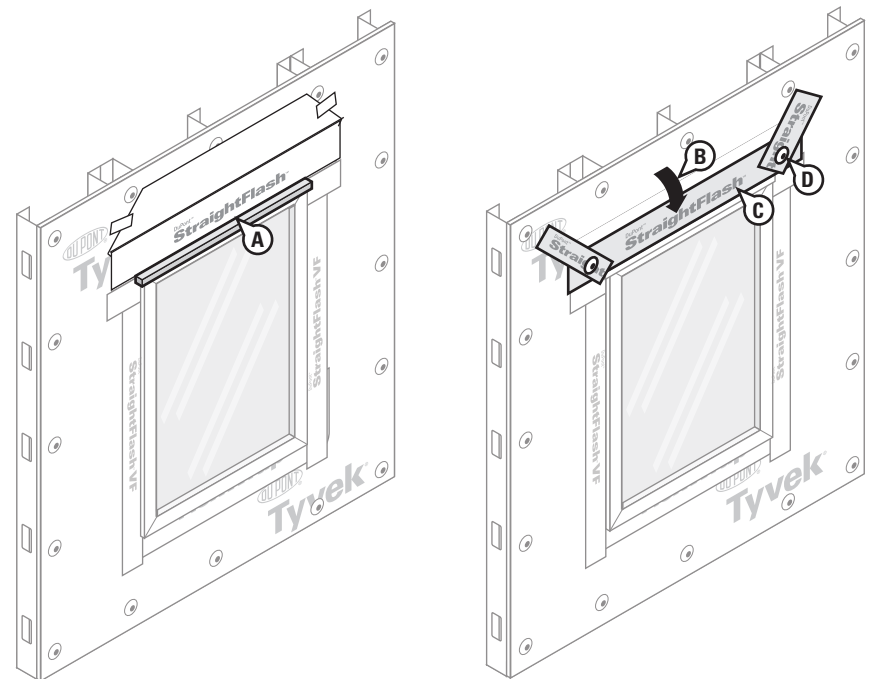

## DuPont Self-Adhered Flashing Systems Installation Guidelines

### STEP 7

#### Interior View

A. Create a continuous perimeter seal using backer rod and sealant or DuPont™ Window and Door Foam on window interior to resist air and water infiltration.

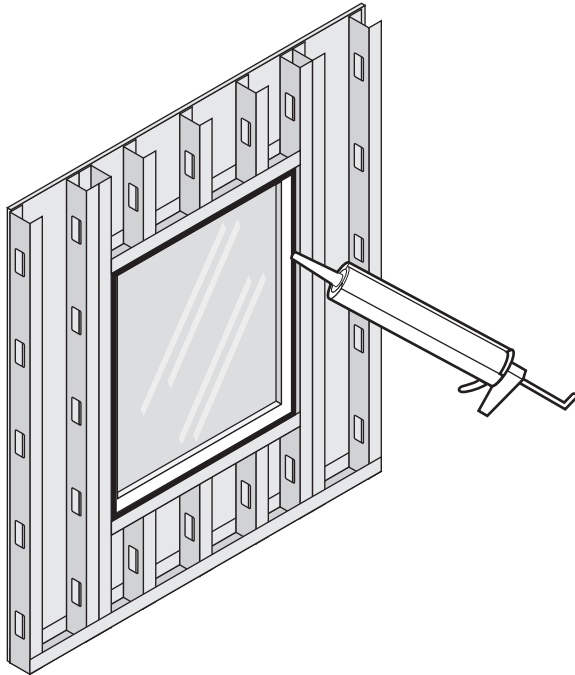

### STEP 7-A (OPTIONAL ALTERNATE BACK DAM PART 1)

A. While the sealant is still wet, as a best practice, install an “L” shaped back dam cut the width of the rough opening so that it contacts the sealant bead and rear of window. Seal by applying recommended sealant along four sides of the exposed back dam. **OPTIONAL:** Apply sealant along all four sides in lieu of back dam.

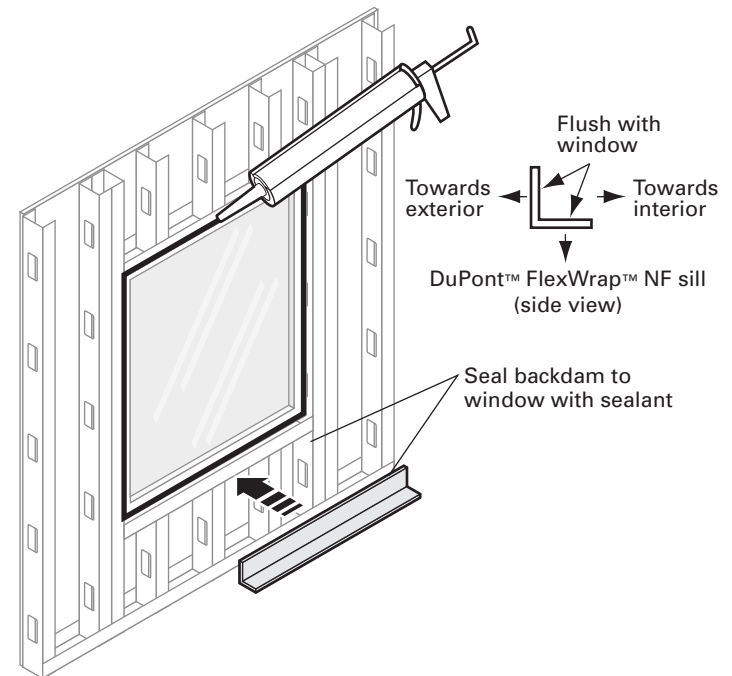

## DuPont Self-Adhered Flashing Systems Installation Guidelines

### STEP 7-B (OPTIONAL ALTERNATE BACK DAM PART 2)

A. Install retention clips around the window to permanently secure it in the rough opening as recommended by window manufacturer to complete installation.

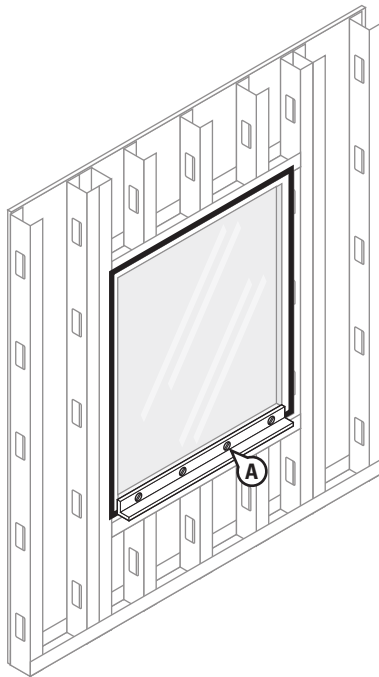



## DuPont Self-Adhered Flashing Systems Installation Guidelines

### Integral Flanged Window

Method applies to following products:

- DuPont™ StraightFlash™
- DuPont™ FlexWrap™ NF
- DuPont™ Flashing Tape

#### STEP 1

Prepare DuPont™ Tyvek® air and water barrier for window installation:

- Make an “I-Cut” in the DuPont™ Tyvek® air and water barrier (a modified I-Cut is also acceptable). For an “I-Cut” begin with a horizontal cut across the bottom and the top of the window frame (for round top windows, the cut should begin 2” above the mull joint, see D). From the center cut straight down to the sill.
- Cut two 45° degree slits a minimum of 8” from the corner of the header to create a flap above the rough opening to expose sheathing or framing members and to allow head flashing installation (see step 5). Flip head flap up and temporarily secure with DuPont™ Tyvek® Tape. Some windows and flashing widths may require longer slits.
- Fold side flaps into rough opening, cut excess flaps, and secure.

**NOTE:** See pages 61-78 of this guide for alternative flashing options for flanged windows aligned with Section 7 of FMA/AAMA 100-12, *Standard Practice for the Installation of Windows with Flanges or Mounting Fins in Wood Framed Construction for Extreme Wind/Water Conditions*.

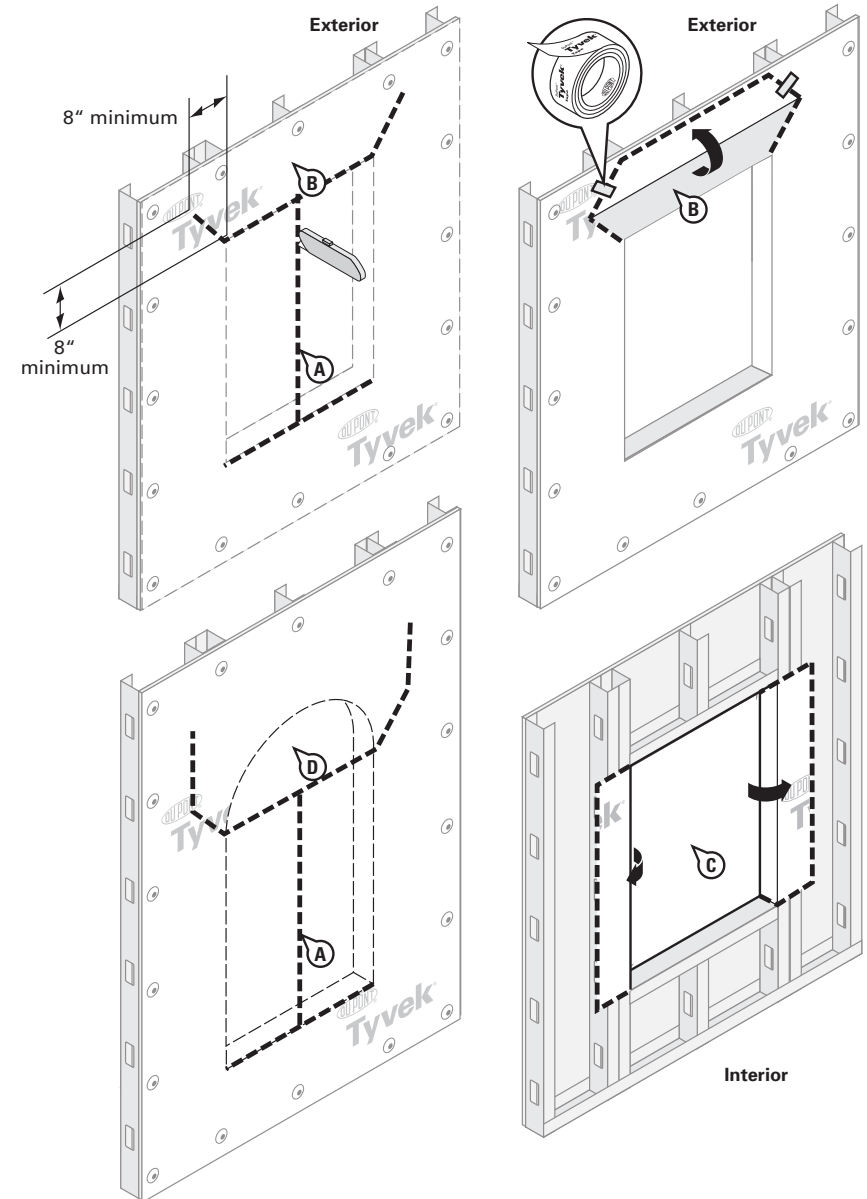

## DuPont Self-Adhered Flashing Systems Installation Guidelines

### STEP 2

- A. Cut DuPont™ FlexWrap™ NF at least 12" longer than width of rough opening sill.
- B. Fold to break perforation. Remove center piece of release paper. Align 6" DuPont™ FlexWrap™ NF with interior edge of sill framing, and adhere into rough opening along sill and up jambs (min 6" on each side).

**OPTIONAL BACK DAM:** Fold 9" DuPont™ FlexWrap™ NF to break perforation. Remove center piece of release paper. Cover horizontal sill leaving 1" of overhang on inside edge of sill for back dam, and adhere into rough opening along sill and up jambs (min 6" on each side). Leave 1" overhang of release paper on DuPont™ FlexWrap™ NF inside rough opening to finish back dam after window installation.

- C. Remove second release paper.
- D. Flex DuPont™ FlexWrap™ NF at bottom corners onto face of wall.

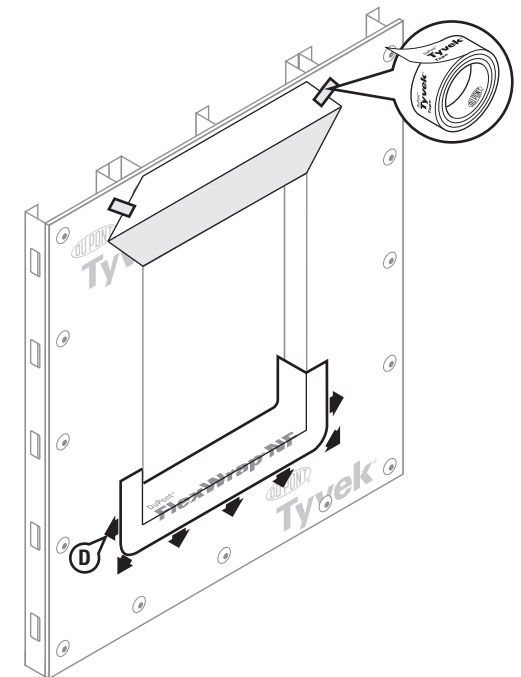
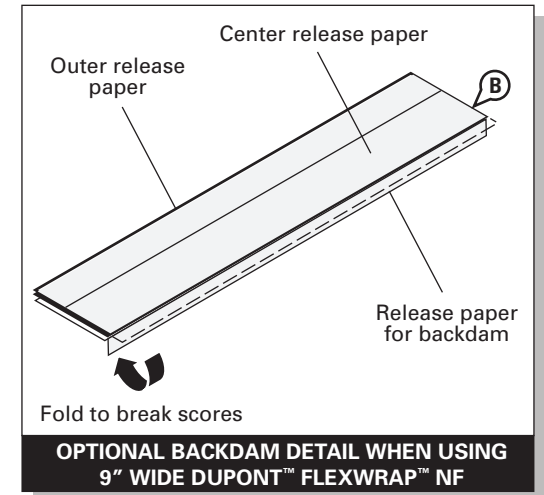
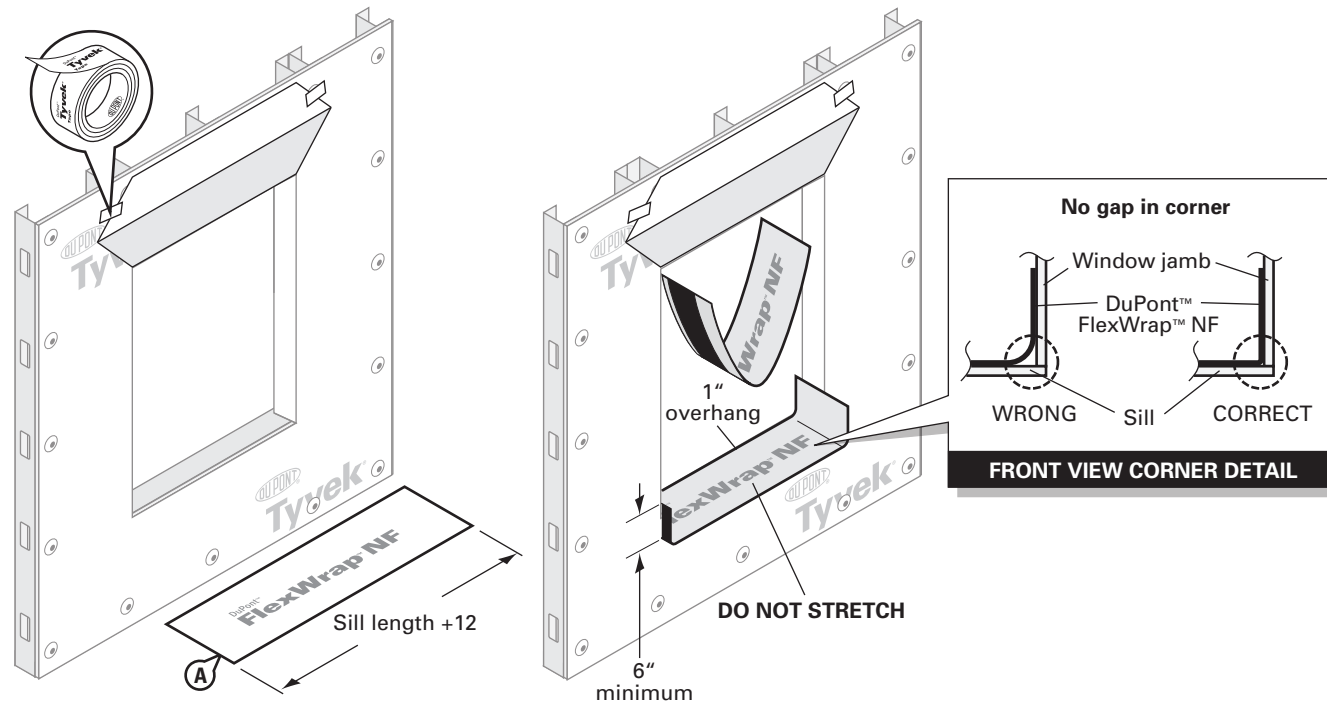

## DuPont Self-Adhered Flashing Systems Installation Guidelines

### STEP 3

- A. Apply continuous bead of sealant at the window head and jambs to wall or back side of window mounting flange. **DO NOT APPLY CONTINUOUS SEALANT BEAD ACROSS BOTTOM SILL FLANGE** to allow for drainage. If sealant is applied to the sill, ensure that there are at least two (2) 2" gaps in the sealant bead for every 4' of window to allow for drainage.

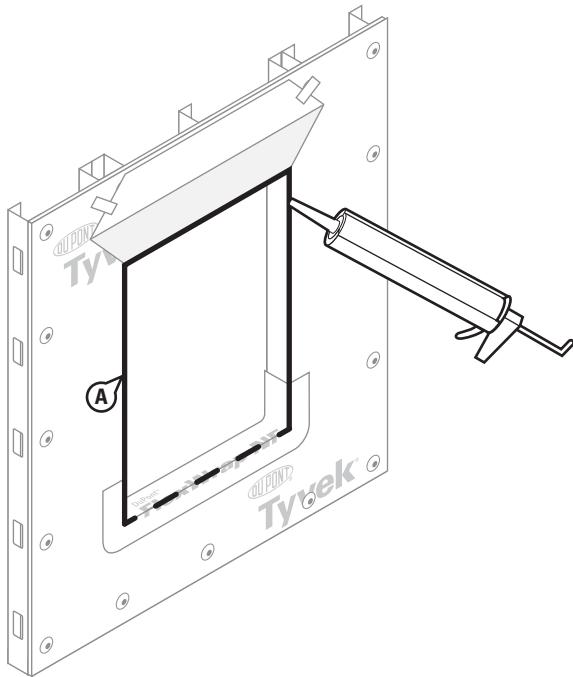

### For rectangular windows

### STEP 4

- A. Install window according to manufacturer's instructions.
- B. Apply DuPont™ Adhesive/Primer to exposed sheathing.
- C. Cut two pieces of DuPont™ StraightFlash™, DuPont™ Flashing Tape\* or DuPont™ FlexWrap™ NF for jamb flashing extending 1" above window head flange and 4" to 6" below bottom edge of sill flashing. Remove release paper and press tightly along sides of window frame.
- D. Cut a piece of DuPont™ StraightFlash™, DuPont™ Flashing Tape\* or DuPont™ FlexWrap™ NF for head flashing, which extends beyond outer edges of jamb flashings. Remove release paper and install completely covering mounting flange and adhering to exposed sheathing or framing members.

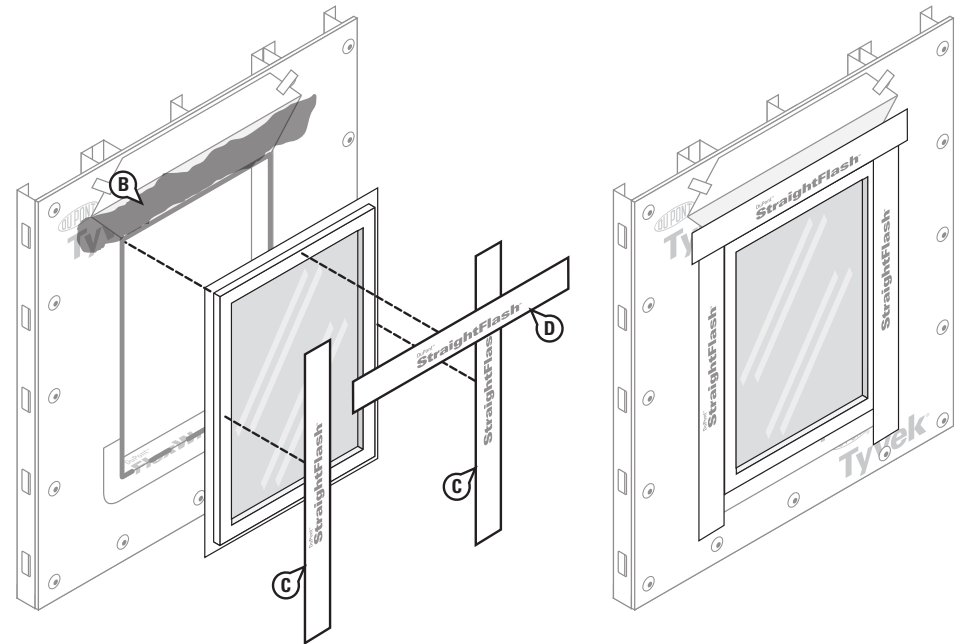

\*DuPont™ Flashing Tape is only permitted for Residential-Use building structures. Residential-Use (Group R) is defined by the 2015/2018 International Building Code.

## DuPont Self-Adhered Flashing Systems Installation Guidelines

### STEP 5

- Flip down upper flap of DuPont™ Tyvek® air and water barrier so it lays flat across head flashing, then **trim 1"-2" above the window opening**.
- Tape along all cuts in DuPont™ Tyvek® air and water barrier and tape across head of the window with 3" DuPont™ Tyvek® Tape, DuPont™ Flashing Tape\* or 4" DuPont™ StraightFlash™. (See General Instructions for when 3" DuPont™ Tyvek® Tape is allowed.)
- Install DuPont™ Tyvek® Wrap Cap Fasteners at appropriate spacing at head.

**NOTE:** For high performance designs or areas of extreme exposure use 4" DuPont™ StraightFlash™ to seal the head flap and install additional mechanical fasteners through the flashing at the head flap and perimeter of window.

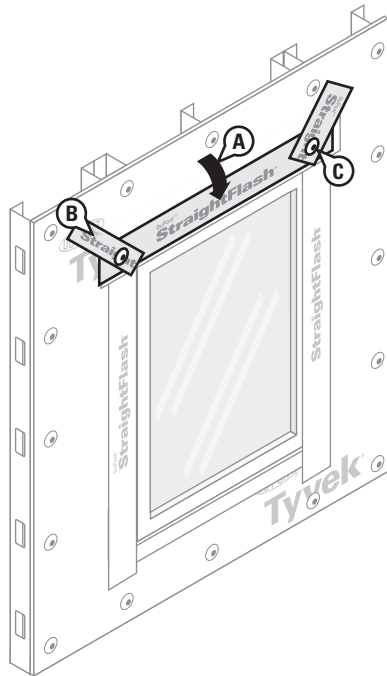

### STEP 6

Final Step

- Seal around the window opening at the interior with sealant (and backer rod as necessary) or DuPont™ Window and Door Foam. Sealant and backer rod, or foam, will also serve as a back dam.
- OPTIONAL:** If back dam is desired use alternate back dam. Install retention clips around the window to permanently secure it in the rough opening as recommended by window manufacturer to complete installation.

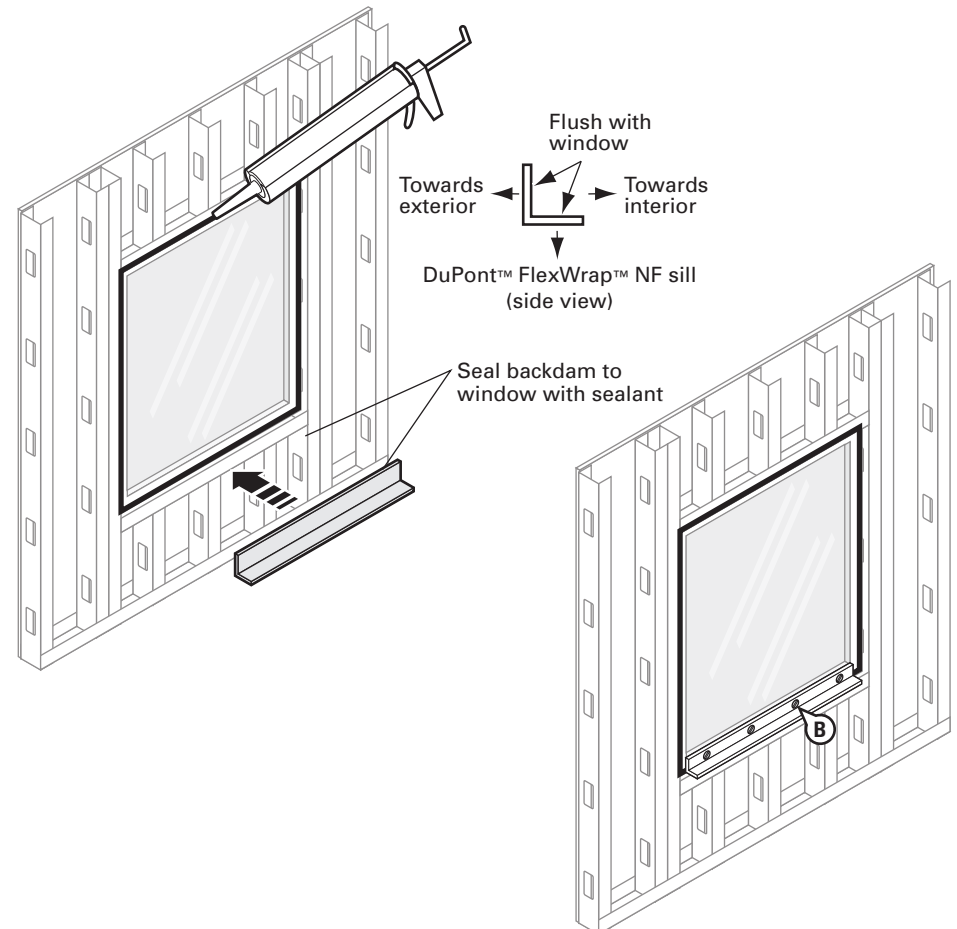

\*DuPont™ Flashing Tape is only permitted for Residential-Use building structures. Residential-Use (Group R) is defined by the 2015/2018 International Building Code.

## DuPont Self-Adhered Flashing Systems Installation Guidelines

### For roundtop windows (integral flange)

#### STEP 4

- Apply continuous bead of sealant at the window head and jambs to wall or back side of window mounting flange. **DO NOT APPLY CONTINUOUS SEALANT BEAD ACROSS BOTTOM SILL FLANGE** to allow for drainage. If sealant is applied to the sill, ensure that there are at least two (2) 2" gaps in the sealant bead for every 4' of window to allow for drainage.
- Apply DuPont™ Adhesive/Primer to the top of the jambs and exposed sheathing.
- Install window according to manufacturer's instructions.
- Cut two pieces of DuPont™ StraightFlash™, DuPont™ Flashing Tape\* or DuPont™ FlexWrap™ NF for jamb flashing extending 1" above window head flange and 4" to 6" below bottom edge of sill flashing. Remove release paper and press tightly along sides of window frame.

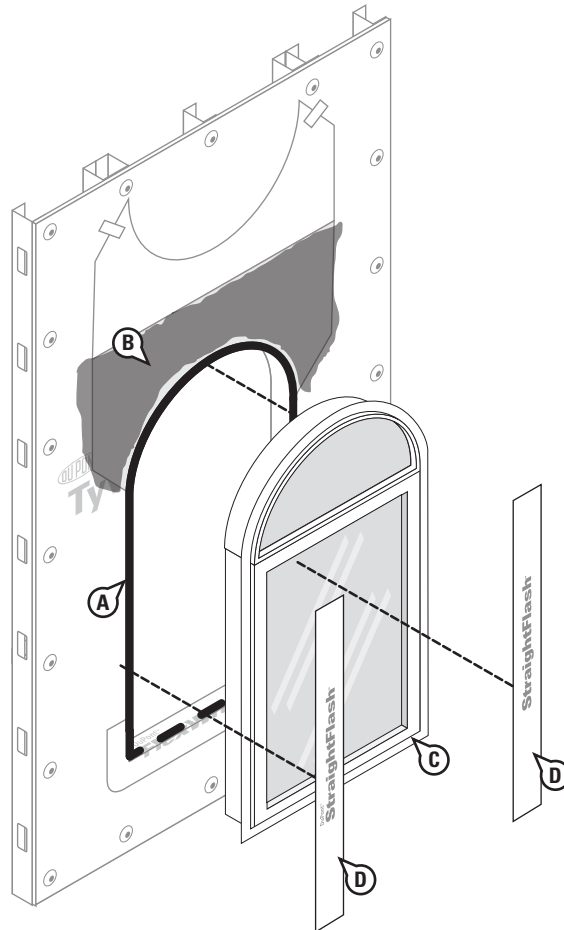

\*DuPont™ Flashing Tape is only permitted for Residential-Use building structures. Residential-Use (Group R) is defined by the 2015/2018 International Building Code.

#### STEP 5

##### Install head flashing

- Cut head flashing at least 12" longer than the arc length (H) of round-top window.
- Remove both release papers and install to conform around top of window, covering entire mounting flange and adhering to exposed sheathing or framing members. Head flashing should overlap jamb flashings at least 6".

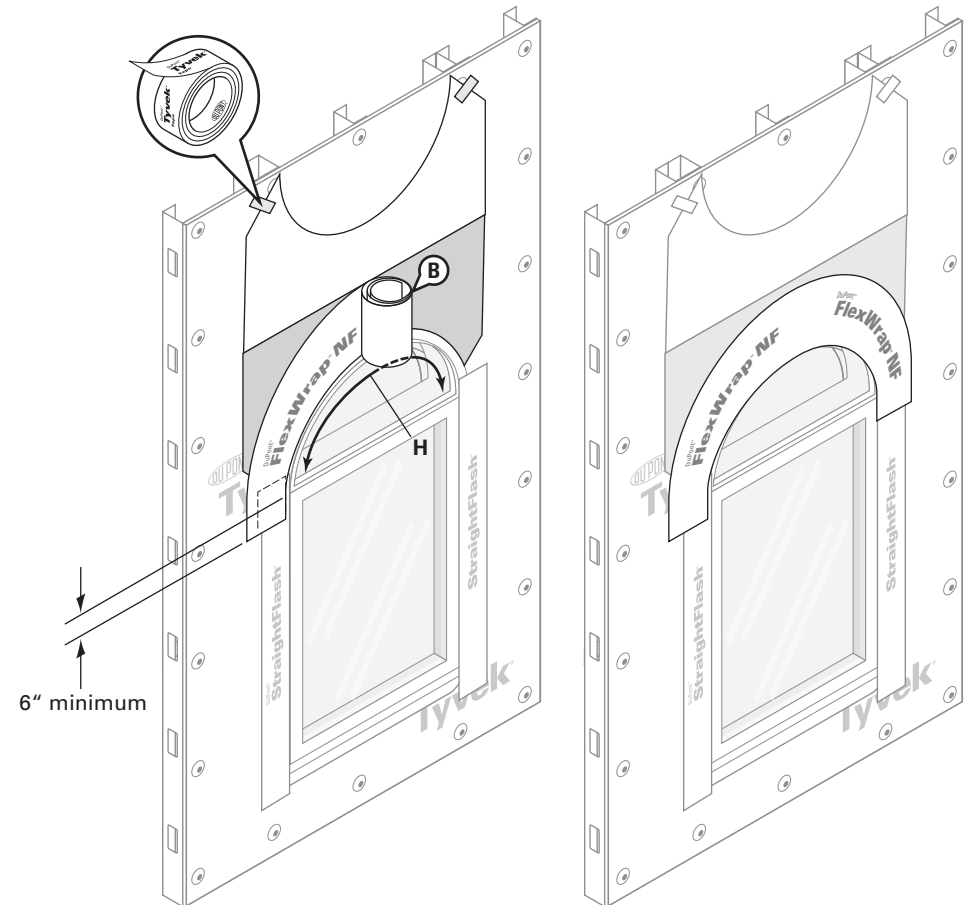

## DuPont Self-Adhered Flashing Systems Installation Guidelines

### STEP 6

- Flip down upper flap of DuPont™ Tyvek® air and water barrier so it lays flat across head flashing, then **trim 1"-2" above the window opening**.
- Tape along all cuts in DuPont™ Tyvek® air and water barrier and across head of the window with 3" DuPont™ Tyvek® Tape, DuPont™ Flashing Tape\* or 4" DuPont™ StraightFlash™. (See General Instructions for when 3" DuPont™ Tyvek® Tape is allowed.)
- Install DuPont™ Tyvek® Wrap Cap Fasteners at appropriate spacing at head.

**NOTE:** For high performance designs or areas of extreme exposure use 4" DuPont™ StraightFlash™ to seal the head flap and install additional mechanical fasteners through the flashing at the head flap and perimeter of window.

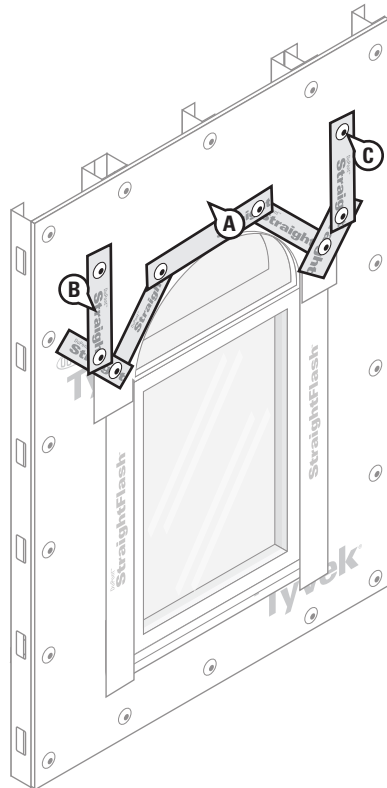

### STEP 7

Final Step

- Seal around the window opening at the interior with sealant (and backer rod as necessary) or DuPont™ Window and Door Foam. Sealant and backer rod, or foam, will also serve as a back dam.
- OPTIONAL:** If back dam is desired, flip up 1" use alternate back dam. Install retention clips around the window to permanently secure it in the rough opening as recommended by window manufacturer to complete installation.

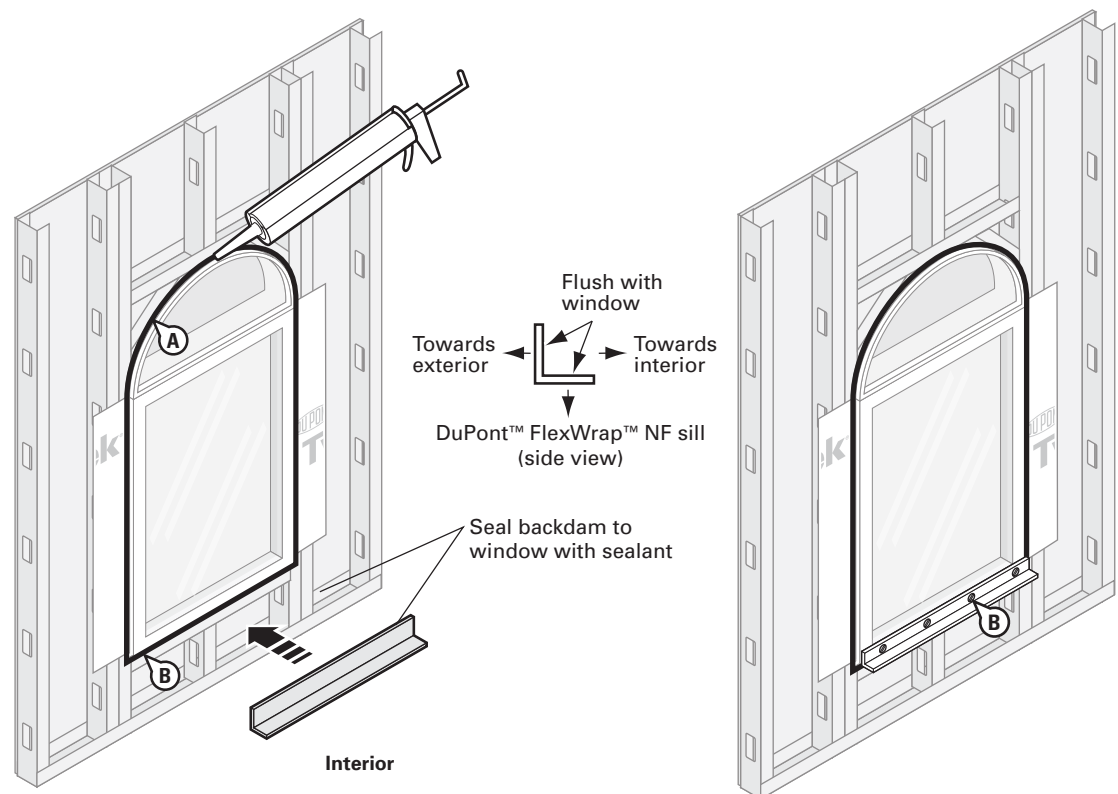

\*DuPont™ Flashing Tape is only permitted for Residential-Use building structures. Residential-Use (Group R) is defined by the 2015/2018 International Building Code.

## DuPont Self-Adhered Flashing Systems Installation Guidelines

### Non-Flanged Window Using DuPont™ StraightFlash™ VF

Method applies to following products:

- DuPont™ StraightFlash™ VF
- DuPont™ FlexWrap™ NF

#### STEP 1

Prepare DuPont™ Tyvek® air and water barrier for window installation. Do not install fasteners within 6" of the sills and jambs, and within 9" of the head of the openings.

A. Make an "I-Cut" in the DuPont™ Tyvek® air and water barrier (a modified I-Cut is also acceptable). For an "I-Cut" begin with a horizontal cut across the bottom and the top of the window frame. From the center cut straight down to the sill.

B. Cut two 45° slits a minimum of 8" from the corner of the header to create a flap above the rough opening to expose sheathing or framing members and to allow head flashing installation (see step 5). Flip head flap up and temporarily secure with DuPont™ Tyvek® Tape. Some windows and flashing widths may require longer slits.

C. Fold side flaps into rough opening, cut excess flaps, and secure. Side flaps should cover interior facing framing stud.

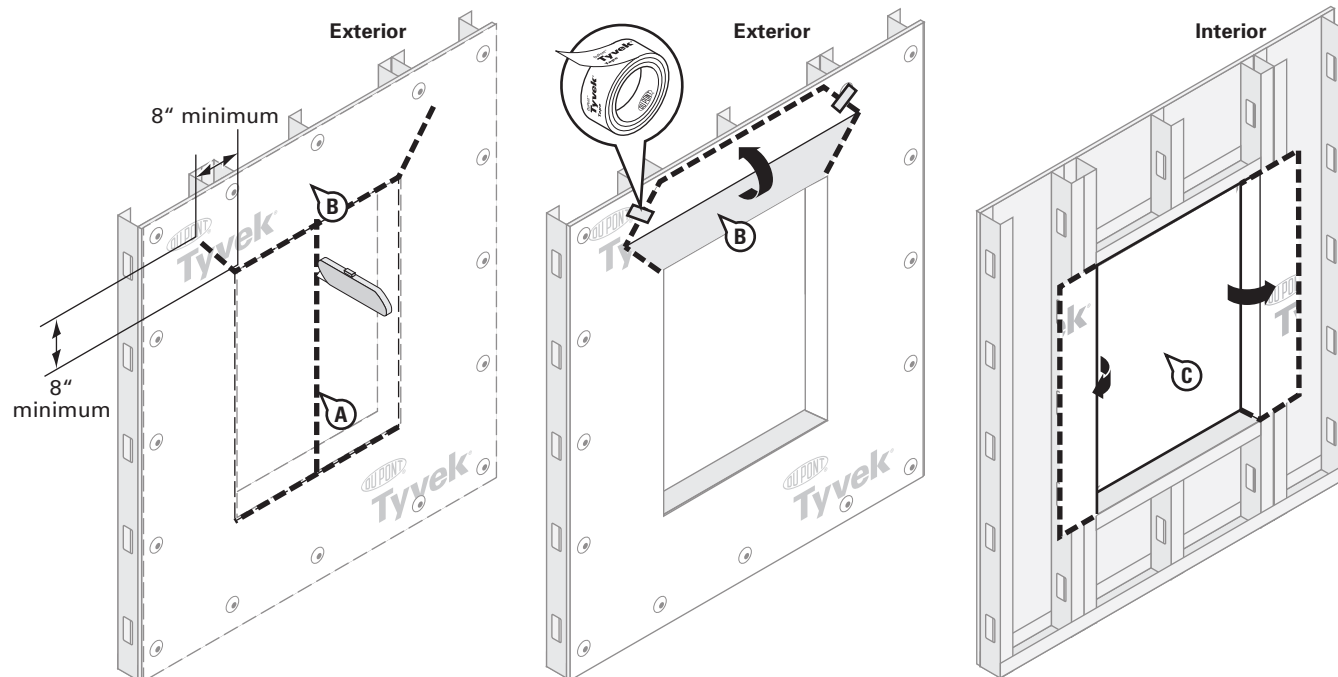

## DuPont Self-Adhered Flashing Systems Installation Guidelines

### STEP 2

- A. Cut DuPont™ FlexWrap™ NF at least 12" longer than width of rough opening sill.
- B. Fold to break perforation. Remove center piece of release paper. Align 6" DuPont™ FlexWrap™ NF with interior edge of sill framing, and adhere into rough opening along sill and up jambs (min 6" on each side).

**OPTIONAL BACK DAM:** Fold 9" DuPont™ FlexWrap™ NF to break perforation. Remove center piece of release paper. Cover horizontal sill leaving 1" of overhang on inside edge of sill for back dam, and adhere into rough opening along sill and up jambs (min 6" on each side). Leave 1" overhang of release paper on DuPont™ FlexWrap™ NF inside rough opening to finish back dam after window installation.

- C. Remove outer release paper.
- D. Flex DuPont™ FlexWrap™ NF at bottom corners onto face of wall.

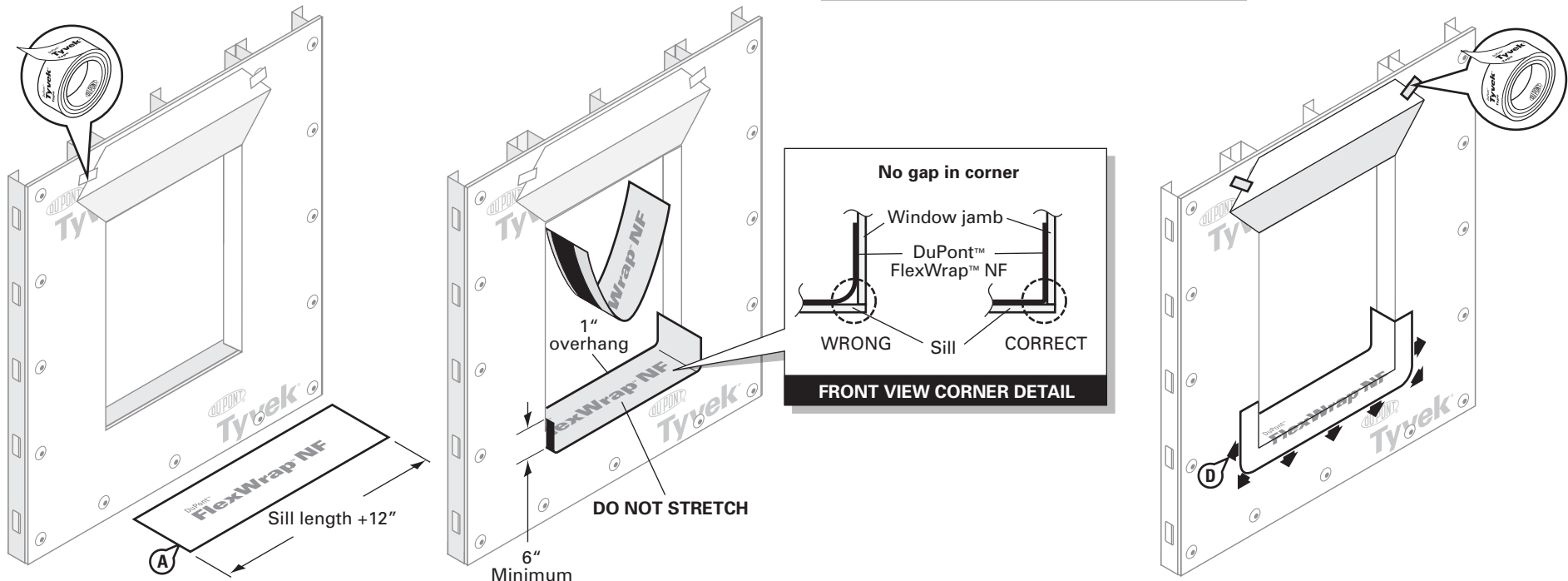
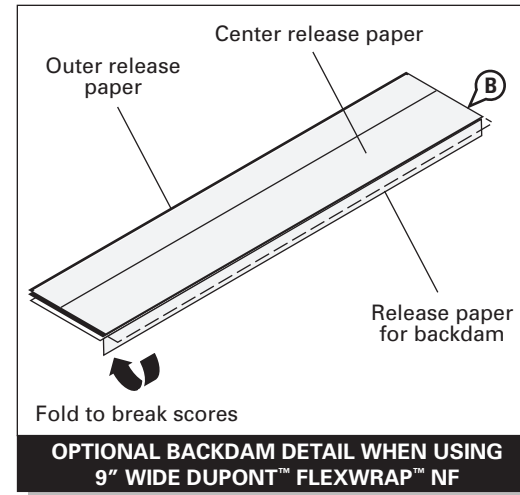



## DuPont Self-Adhered Flashing Systems Installation Guidelines

### STEP 3

- A. Prepare head flashing by cutting a piece of DuPont™ StraightFlash™ VF at least 12" LONGER than the head length. Before flashing, prime window fins and casings with DuPont™ Adhesive/Primer.
- B. Break the scored release paper on one side of the head flashing by folding it back and forth upon itself.
- C. Center the flashing on the window head and position so that it contacts the window frame and interior side of the front flange. Remove the outer release paper and adhere the flashing to the window frame. Use the inner release paper to form a tight seal in the corner.
- D. Remove the inner release paper and adhere the flashing to the back of the aluminum window fin and casing.
- E. At the corner of the window frame, cut the DuPont™ StraightFlash™ VF along the corner at a 45° angle.
- F. Fold the DuPont™ StraightFlash™ VF down flat.

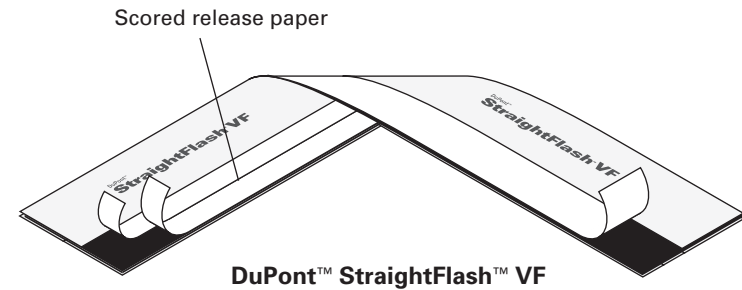

#### Top View

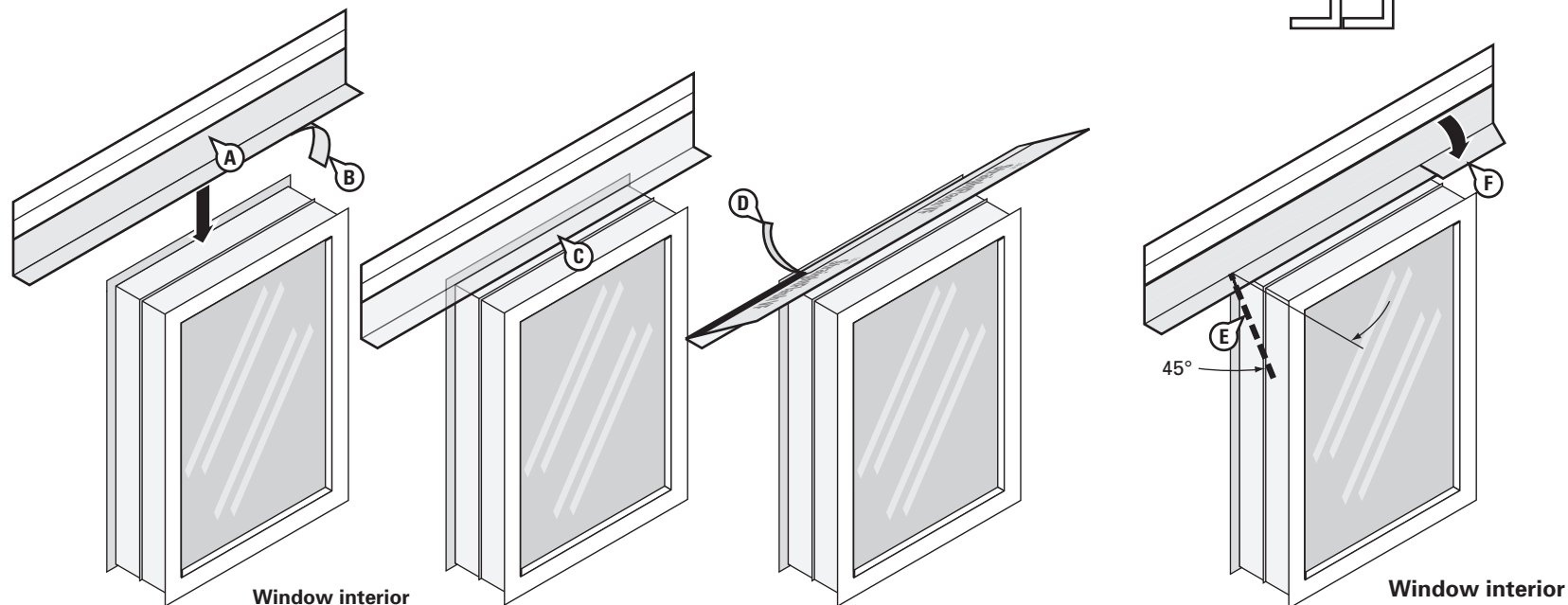
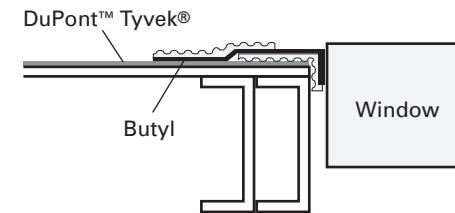

## DuPont Self-Adhered Flashing Systems Installation Guidelines

### STEP 4

- A. Prepare jamb flashing by cutting a piece of DuPont™ StraightFlash™ VF at least 6" LONGER than the jamb.
- B. Break the scored release paper on one side of the jamb flashing by folding it back and forth upon itself.
- C. Position the flashing so that it contacts the window frame and interior side of the aluminum window fin. Ensure that the jamb flashing is positioned 1-1/2 inch below the top edge of the head flashing. Jamb flashing adhesive must come in contact with head flashing adhesive and overlap by 1".
- D. Remove the outer release paper and adhere the flashing to the window frame. Use the inner release paper to form a tight seal in the corner.
- E. Remove the inner release paper and adhere the flashing to the back of the aluminum window fin.
- F. At the corner of the window frame, cut the DuPont™ StraightFlash™ VF along the corner and fold it down flat to adhere against the head flashing.
- G. Cut a 2" x 4" piece of DuPont™ FlexWrap™ NF and patch each corner.

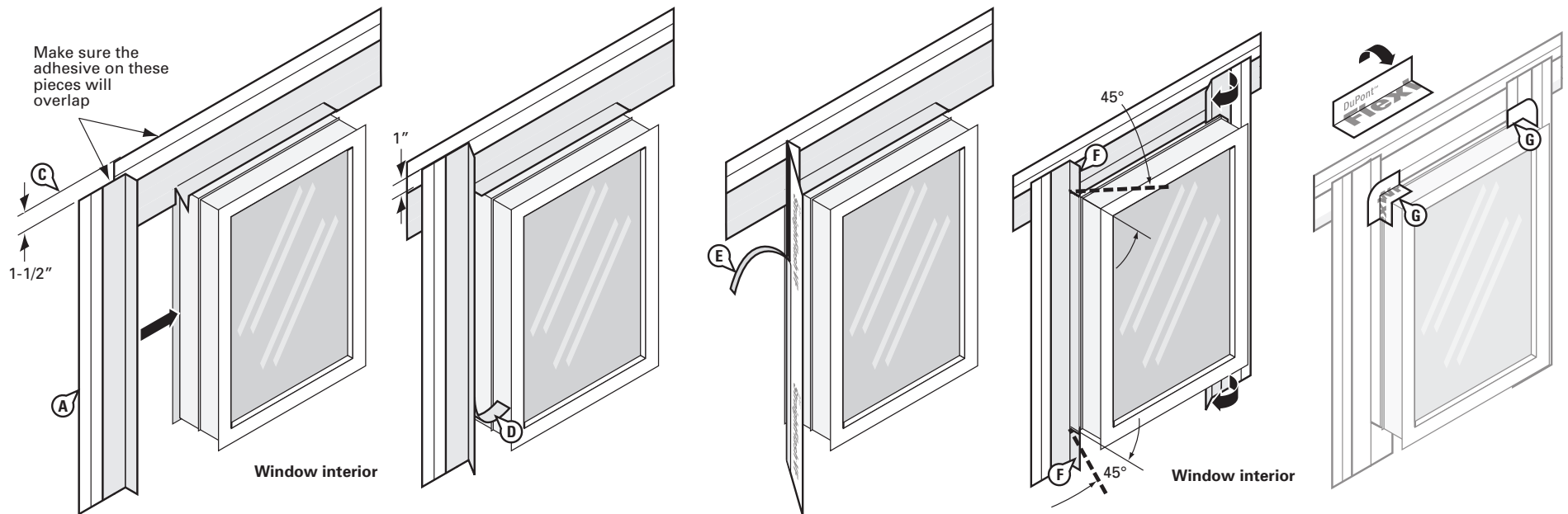

## DuPont Self-Adhered Flashing Systems Installation Guidelines

### STEP 5

- Apply DuPont™ Adhesive/Primer to the top of the jambs and exposed sheathing.
- Install window according to manufacturer's installation instructions. If sealant is applied to the sill, ensure that there are at least two (2) 2" gaps in the sealant bead for every 4' of window to allow for drainage.
- Remove the remaining release paper from the DuPont™ StraightFlash™ VF jamb flashing and press firmly to adhere it to the DuPont™ Tyvek® air and water barrier.
- Remove the release paper at the head and adhere it to the wall surface.
- OPTIONAL:** Cover exposed butyl with DuPont™ StraightFlash™ or DuPont™ Tyvek® Tape.

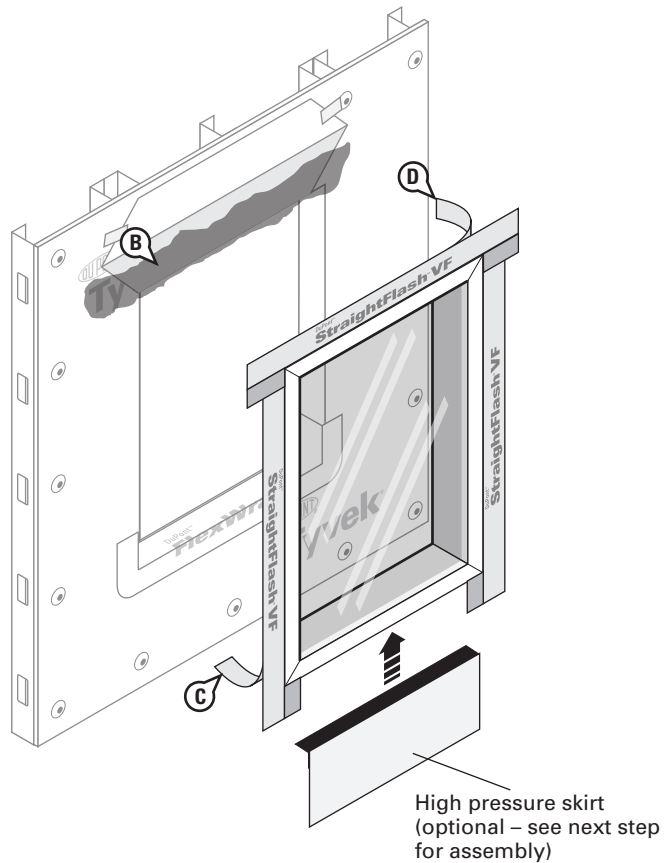

### STEP 5 – OPTIONAL HIGH PRESSURE SKIRT

- Create the high pressure skirt by cutting a piece of DuPont™ Tyvek® weather barrier 1" wider than the width of window opening and approximately 10" in depth.
- Attach skirt to underside of window using a piece of 4" DuPont™ StraightFlash™ cut to the same width as the skirt.

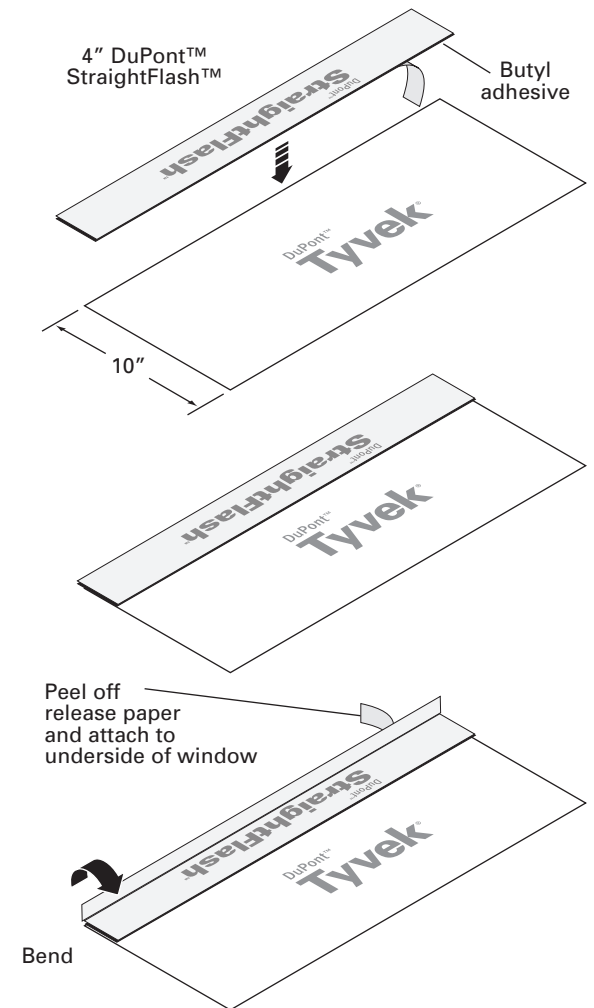

## DuPont Self-Adhered Flashing Systems Installation Guidelines

### STEP 6

- A. Cut a piece of metal or vinyl drip cap slightly longer than the window's width and place a bead of recommended sealant on the rear side. Install the drip cap tight against the window head and cover the top edge with DuPont™ StraightFlash™ or DuPont™ Tyvek® Tape.

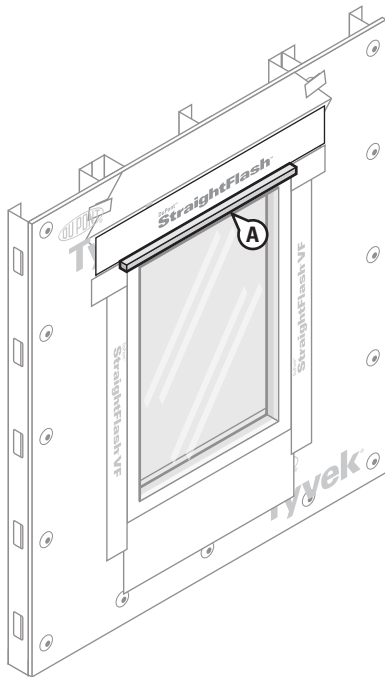

### STEP 7

- A. Flip down upper flap of DuPont™ Tyvek® air and water barrier so it lays flat across head flashing, then **trim 1"-2" above the window opening.**
- B. Tape along all cuts in DuPont™ Tyvek® air and water barrier and tape across drip cap with 3" DuPont™ Tyvek® Tape or 4" DuPont™ StraightFlash™. (See General Instructions for when 3" DuPont™ Tyvek® Tape is allowed.)
- C. Install DuPont™ Tyvek® Wrap Cap Fasteners at jambs and head flap at recommended spacing.

**NOTE:** For high performance designs or areas of extreme exposure use 4" DuPont™ StraightFlash™ to seal the head flap and install additional mechanical fasteners through the flashing at the head flap and perimeter of window.

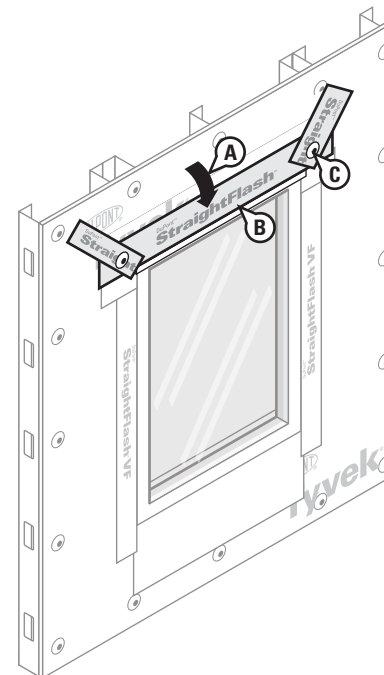

### Top View

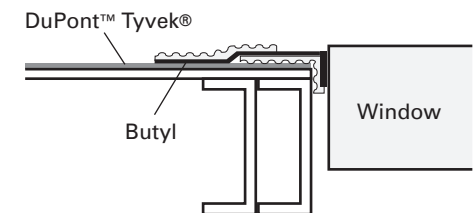

## DuPont Self-Adhered Flashing Systems Installation Guidelines

### STEP 8

- A. Install DuPont™ Tyvek® Wrap Cap Fasteners through the skirt.
- B. Secure sides of high pressure skirt to weather barrier with DuPont™ StraightFlash™ and skip tape bottom with 3" DuPont™ Tyvek® Tape or 4" DuPont™ StraightFlash™. Skip taping provides weeps that allows drainage behind the skirt.

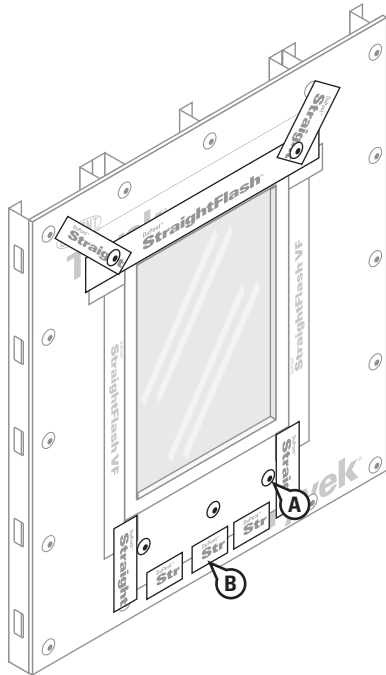

### STEP 9

Final Step

- A. Seal around the window opening at the interior with sealant (and backer rod as necessary) or DuPont™ Window and Door Foam. Sealant and backer rod, or foam, will also serve as a back dam.
- B. **OPTIONAL:** If back dam is desired use alternate back dam.

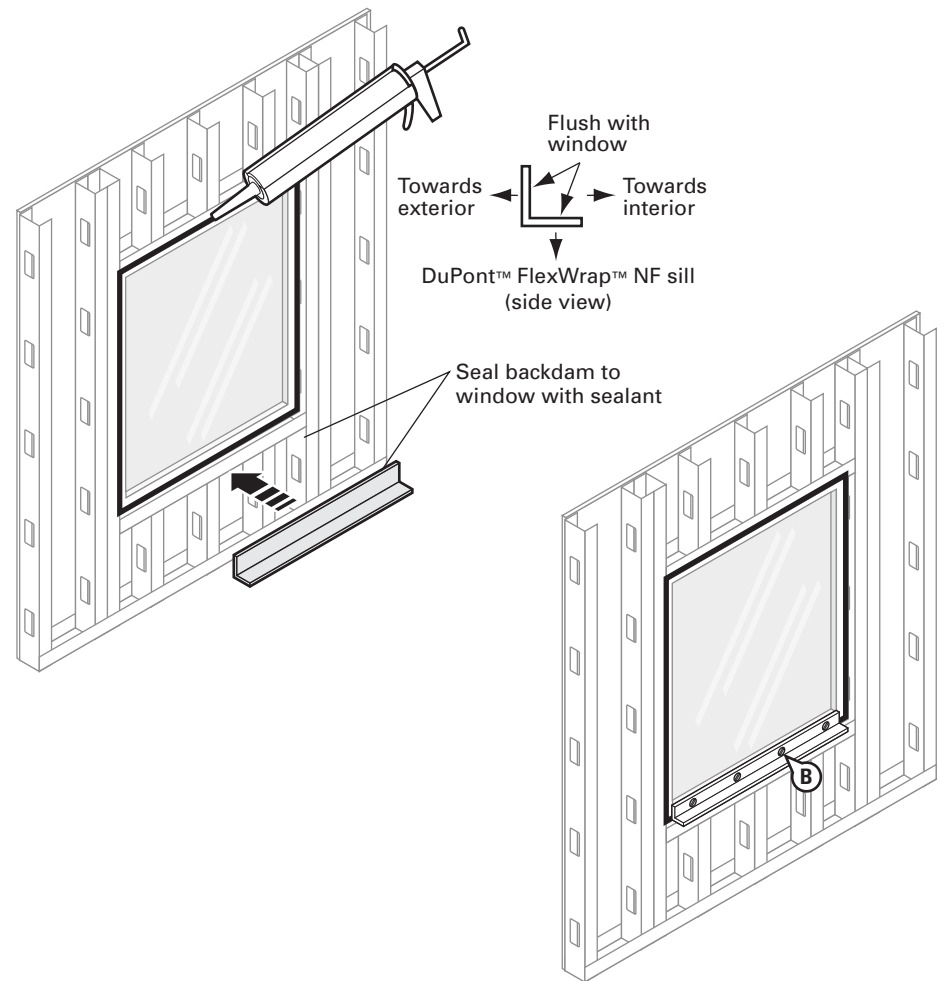

## DuPont Self-Adhered Flashing Systems Installation Guidelines

### Store front Window on Slab

Method applies to following products:

- DuPont™ StraightFlash™
- DuPont™ FlexWrap™ NF

#### STEP 1

A. Cut rough opening in sheathing for window.

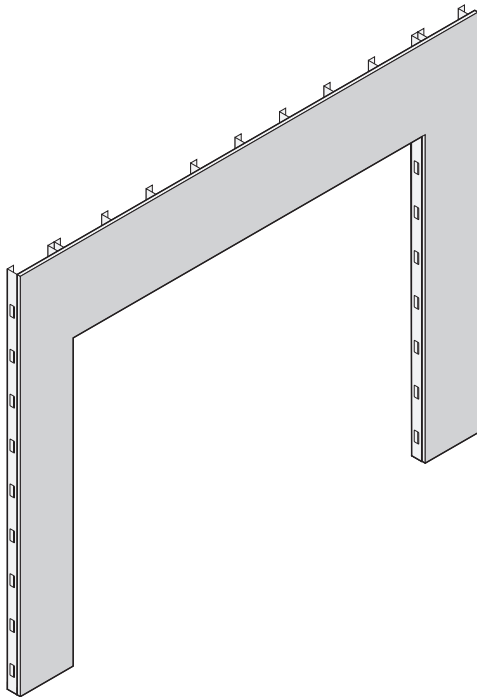

#### STEP 2

A. Wrap wall as shown in *DuPont™ Tyvek® Mechanically Fastened Air and Water Barrier Installation Guidelines for Buildings Greater Than 4 Stories* that can be found at [www.weatherization.tyvek.com](http://www.weatherization.tyvek.com). Do not install fasteners within 6" of the jambs of the openings and within 9" of the head of the openings.

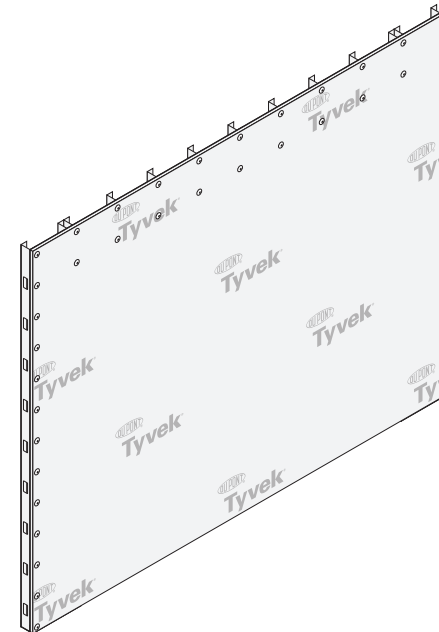

## DuPont Self-Adhered Flashing Systems Installation Guidelines

### STEP 3

Prepare air and water barrier for window installation.

- A. Cut an opening in the DuPont™ Tyvek® air and water barrier using a square cut around the perimeter of the rough opening.
- B. Cuts should be made along the dashed indicated lines. (Ensure that the DuPont™ Tyvek® air and water barrier is cut flush with the sheathing and is not wrapped into the rough opening.)
- C. Cut a head flap at a 45° angle to expose 8" of sheathing to allow for head flashing installation.

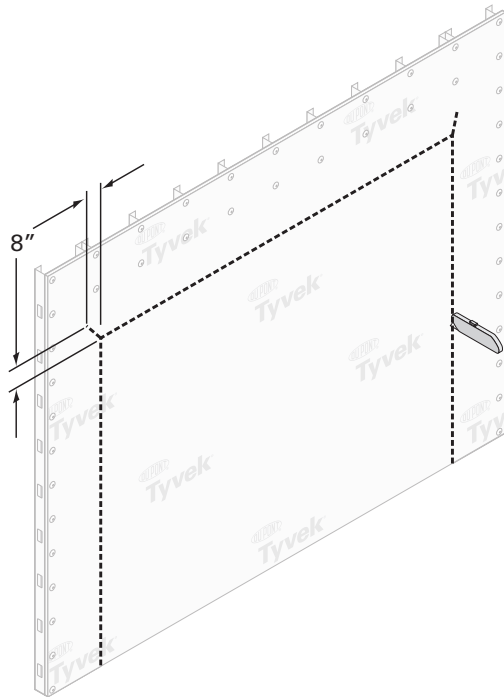

### STEP 4

- A. Flip the head flap up to expose the sheathing and temporarily secure with tape.
- B. Temporarily secure DuPont™ Tyvek® air and water barrier with DuPont™ Tyvek® Tape around rough opening before flashing is installed to help facilitate flashing installation.

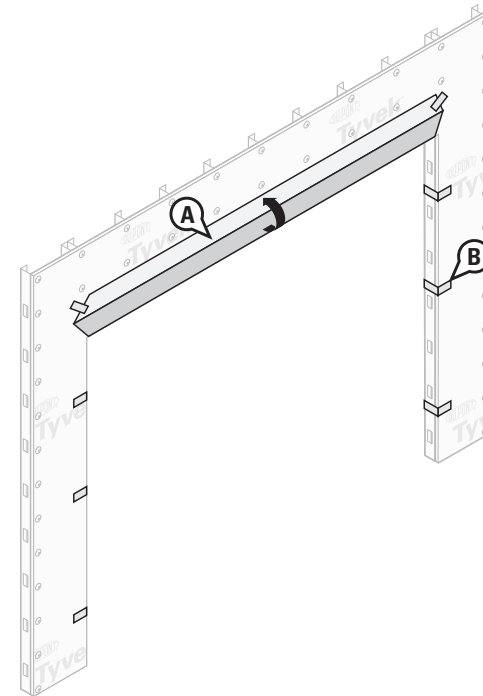

## DuPont Self-Adhered Flashing Systems Installation Guidelines

### STEP 5

- A. Prepare the sill flashing per manufacturer's recommendation and seal the corner pan flashing with sealant.
- B. Inspect installation surface to ensure surface is free of dirt or substances that could interfere with adhesion as well as any sharp protrusions.

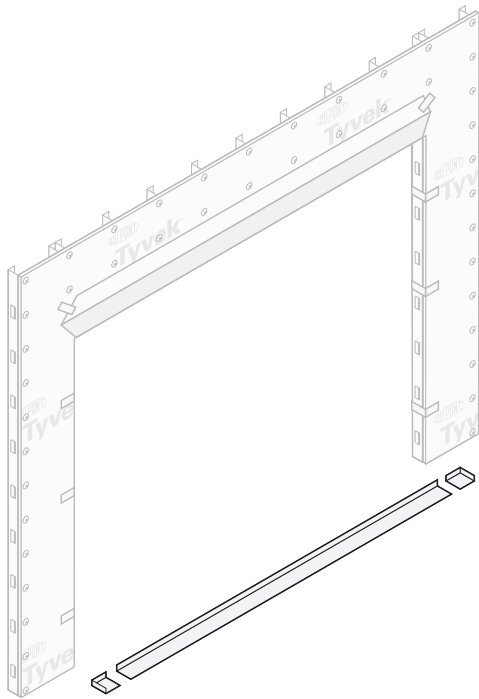

### STEP 6

- A. Shim, level and anchor pan per manufacturer's instructions flashing to concrete.
- B. Seal corner pan flashing seams with sealant.

**OPTION 2:** An alternate approved flashing method is to install DuPont™ StraightFlash™ using installation method outlined in "Non-Flanged Window Using DuPont™ StraightFlash™ VF" on page 39.

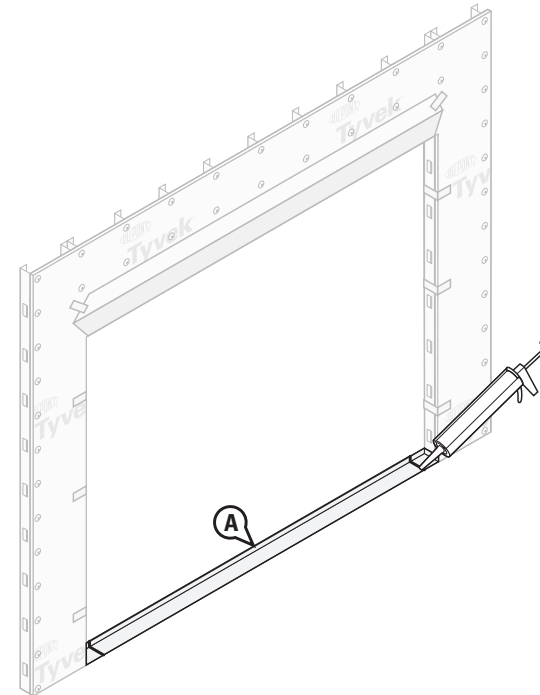



## DuPont Self-Adhered Flashing Systems Installation Guidelines

### STEP 7

- A. Wrap 9" DuPont™ StraightFlash™ into the rough opening at each jamb and onto wall face. The flashing should align with the interior edge of the jamb framing. Cut the jamb flashing the vertical length of the rough opening.
- B. Jamb flashing should be long enough to overlap the sill flashing by at least 2" and be overlapped by future head flashing by at least 2".

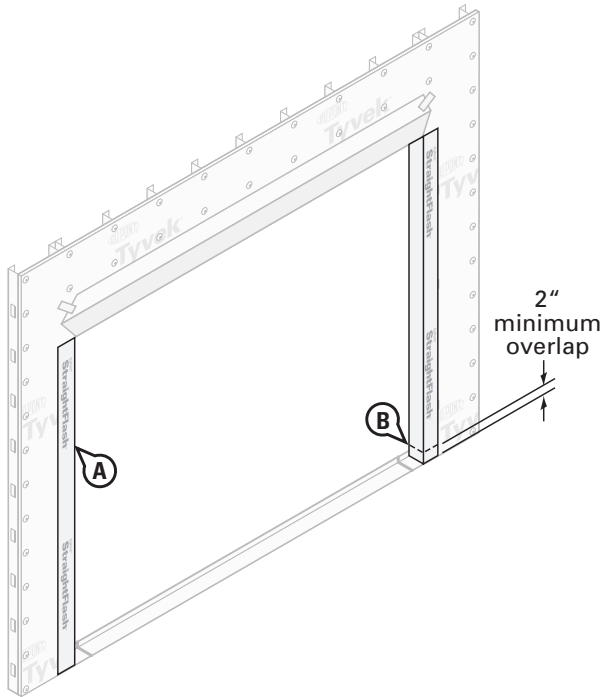

### STEP 8

- A. Apply DuPont™ Adhesive/Primer to the top of the jambs and exposed sheathing.

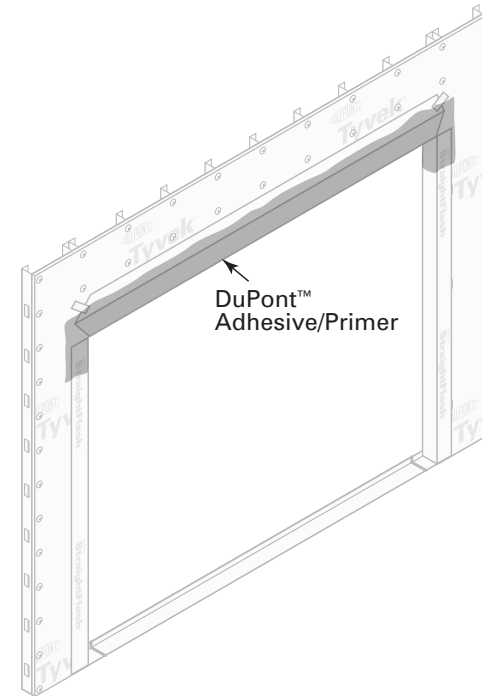

## DuPont Self-Adhered Flashing Systems Installation Guidelines

### STEP 9

- A. Adhere DuPont™ FlexWrap™ NF to the head. Make sure the DuPont™ FlexWrap™ NF is cut long enough to overlap the jamb flashing by at least 2”.
- B. Use sufficient width of DuPont™ FlexWrap™ NF to avoid reverse shingling of flashing at the jamb and head interface. See detail below.

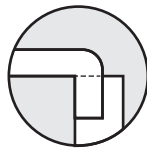
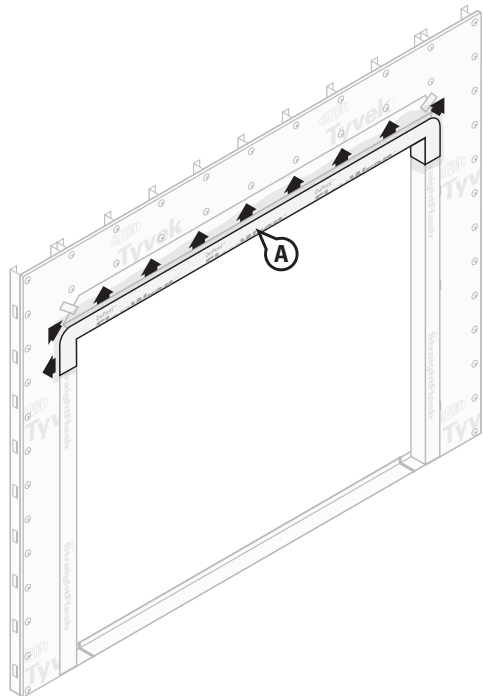

**INCORRECT**  
DuPont™ FlexWrap™ NF  
reverse flashed

### STEP 10

- A. Flip down the head flap and **trim 1”-2” above the window opening**. Terminate flap along the top of the window with 3” DuPont™ Tyvek® Tape or 4” DuPont™ StraightFlash™. (See General Instructions for when 3” DuPont™ Tyvek® Tape is allowed).
- B. Apply 4” DuPont™ StraightFlash™ over the diagonal seams.
- C. Install remaining DuPont™ Tyvek® Wrap Cap Fasteners at head per the recommended spacing (every 12” to 18” depending on the vertical stud line).

**NOTE:** For high performance designs or areas of extreme exposure use 4” DuPont™ StraightFlash™ to seal the head flap and install additional mechanical fasteners through the flashing at the head flap and perimeter of window.

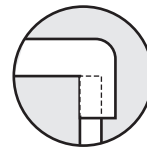
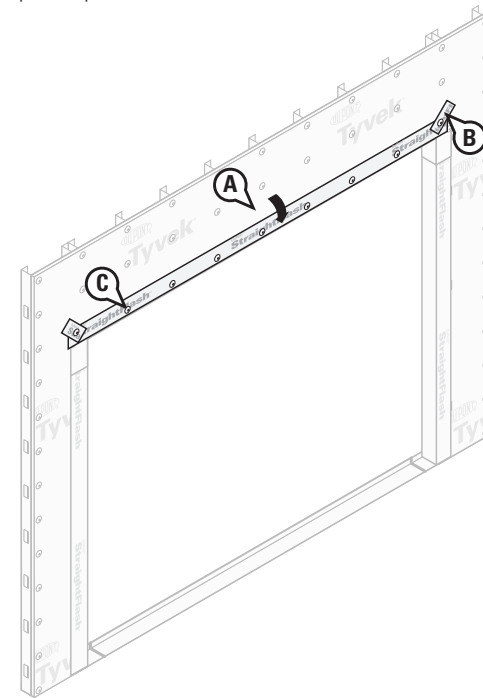

**CORRECT**  
DuPont™ StraightFlash™  
overlaps DuPont™  
FlexWrap™ NF

## DuPont Self-Adhered Flashing Systems Installation Guidelines

### STEP 11

- A. Install store front window per manufacturer's installation instructions.
- B. Glaze windows per manufacturer's instructions.

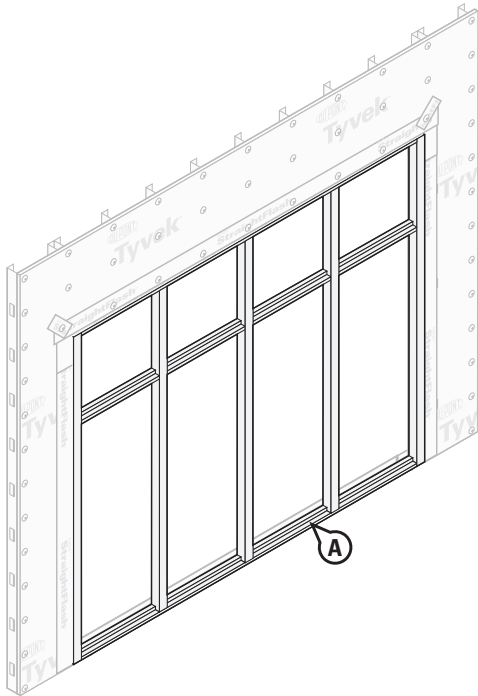

### STEP 12

- A. Create a continuous perimeter seal using backer rod and sealant or DuPont™ Window and Door Foam on window interior to resist air and water infiltration.

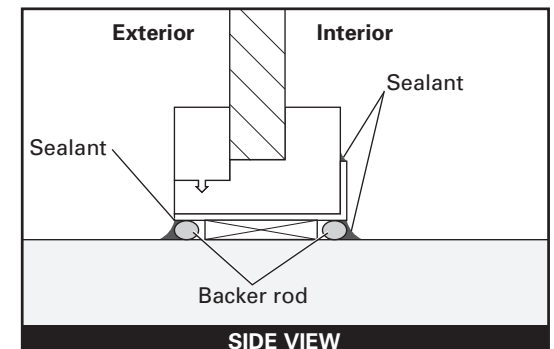
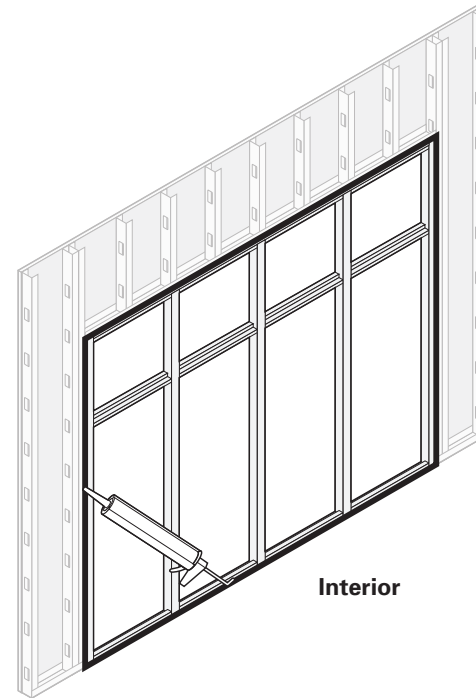

## DuPont Self-Adhered Flashing Systems Installation Guidelines

### Store front Window on Knee Wall

Method applies to following products:

- DuPont™ StraightFlash™
- DuPont™ FlexWrap™ NF

#### STEP 1

A. Cut rough opening in sheathing for window. Ensure that sheathing is cut flush with, or slightly below the sill framing to allow for positive drainage.

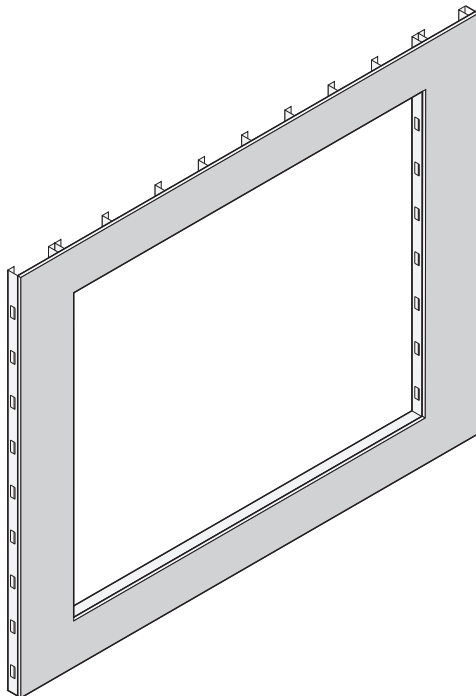

#### STEP 2

A. Wrap wall as shown in *DuPont™ Tyvek® Mechanically Fastened Air and Water Barrier Installation Guidelines for Buildings Greater Than 4 Stories* that can be found at [www.weatherization.tyvek.com](http://www.weatherization.tyvek.com). Do not install fasteners within 6" of the sills and jambs of the openings and within 9" of the head of the openings.

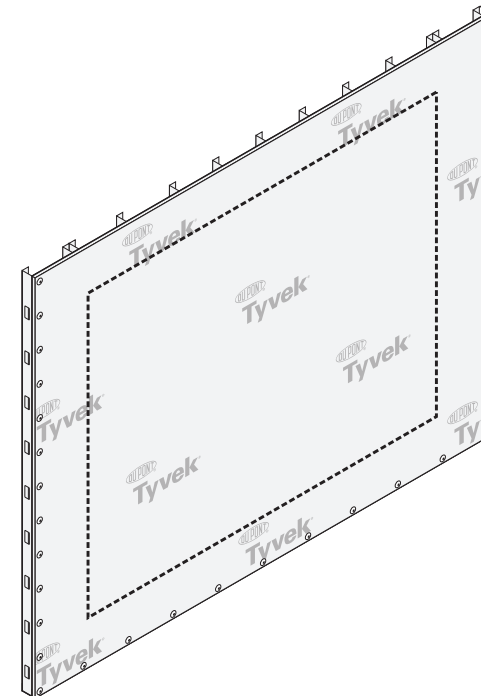

## DuPont Self-Adhered Flashing Systems Installation Guidelines

### STEP 3

Prepare air and water barrier for window installation.

- A. Cut an opening in the DuPont™ Tyvek® air and water barrier using a square cut around the perimeter of the rough opening.
- B. Cuts should be made along the dashed indicated lines. (Ensure that the DuPont™ Tyvek® air and water barrier is cut flush with the sheathing and is not wrapped into the rough opening.)
- C. Cut a head flap at a 45° angle to expose 8" of sheathing to allow for head flashing installation.

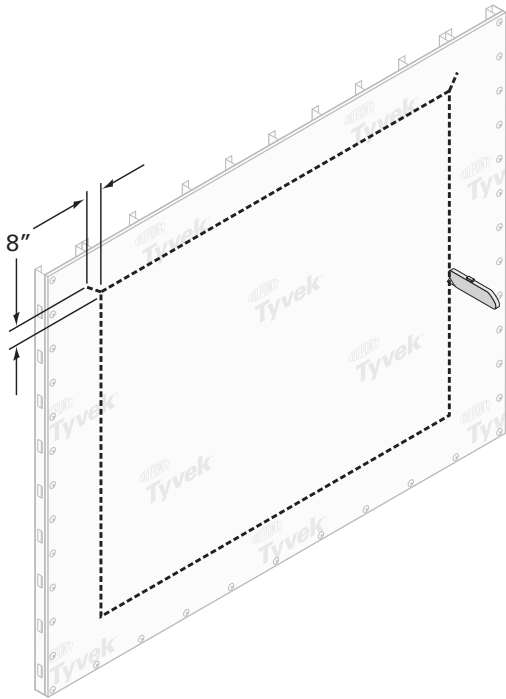

### STEP 4

- A. Flip the head flap up to expose the sheathing and temporarily secure with tape.
- B. Temporarily secure DuPont™ Tyvek® air and water barrier with DuPont™ Tyvek® Tape around rough opening before flashing is installed to help facilitate flashing installation.

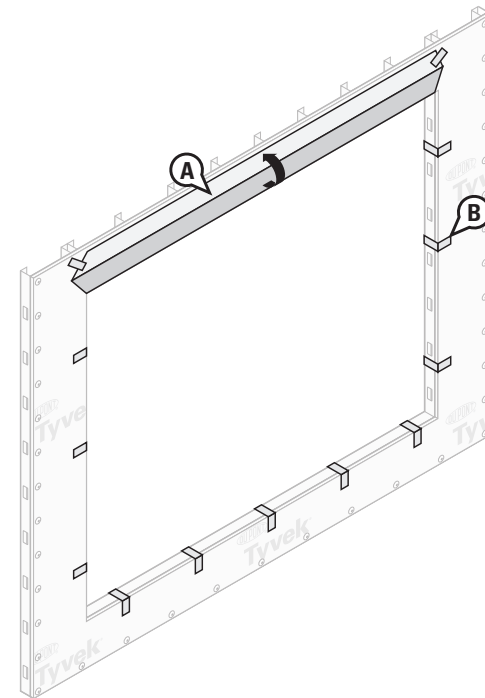

## DuPont Self-Adhered Flashing Systems Installation Guidelines

### STEP 5

- A. Prepare the sill flashing by cutting a piece of DuPont™ FlexWrap™ NF that is at least 12" longer than sill length. Use 6" DuPont™ FlexWrap™ NF for 2" x 4" framing and 9" DuPont™ FlexWrap™ NF for 2" x 6" framing.
- B. Inspect installation surface to ensure surface is free of dirt or substances that could interfere with adhesion as well as any sharp protrusions.

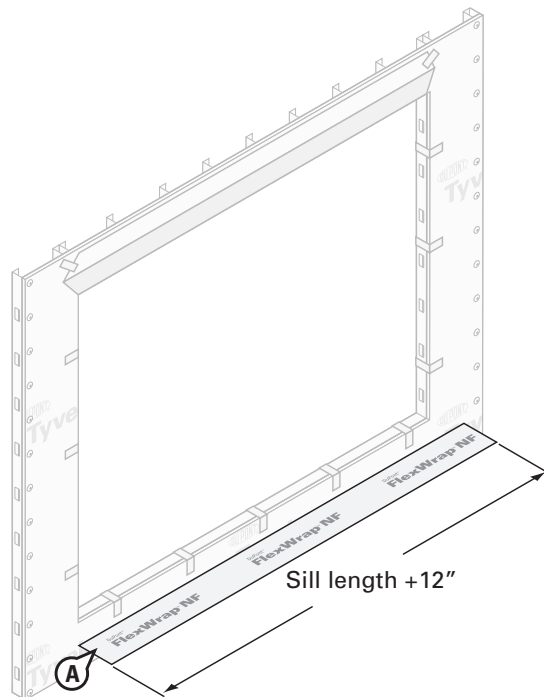

### STEP 6

- A. Install the sill flashing. Remove the largest strip of release paper, align the flashing with the interior edge of sill, and install into rough opening across sill and up jambs (min 6".) Apply working from the middle of the sill towards the sides. Secure DuPont™ FlexWrap™ NF tightly into the corners by first working in along the sill before adhering up the jambs.

**DO NOT STRETCH MATERIAL ALONG THE SILL OR JAMBS.**

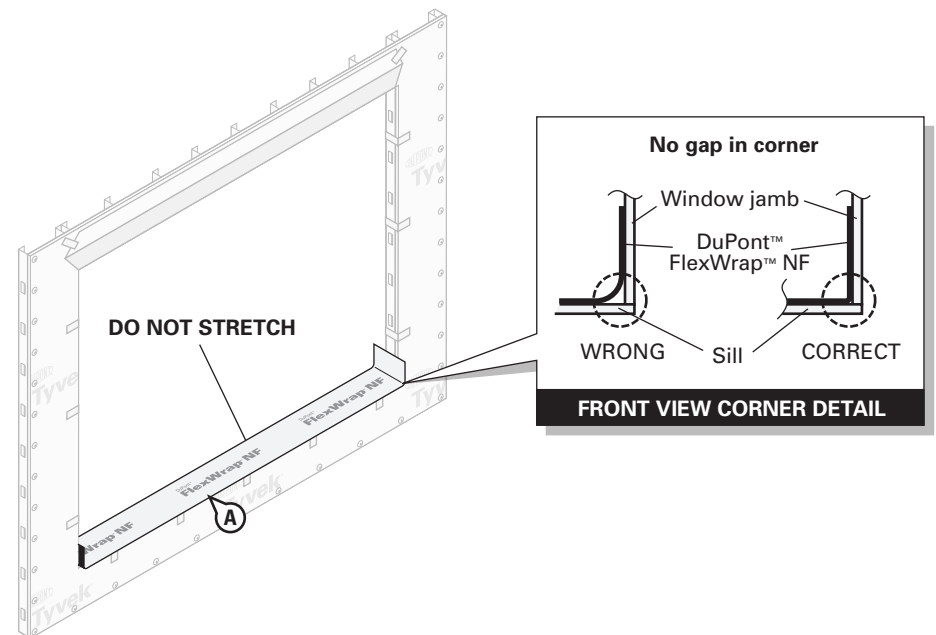

## DuPont Self-Adhered Flashing Systems Installation Guidelines

### STEP 7

- Remove second half of the release paper.
- Fan DuPont™ FlexWrap™ NF at bottom corners and adhere onto face of wall.
- Firmly press sill flashing to ensure full adhesion on all surfaces. Eliminate wrinkles and bubbles by smoothing surface and repositioning as necessary.
- Shim, level and anchor sill pan flashing and seal corner seams per manufacturer's instructions with sealant.

**OPTION 2:** An alternate approved flashing method is to install DuPont™ StraightFlash™ using installation method outlined in "Non-Flanged Window Using DuPont™ StraightFlash™ VF" on page 39.

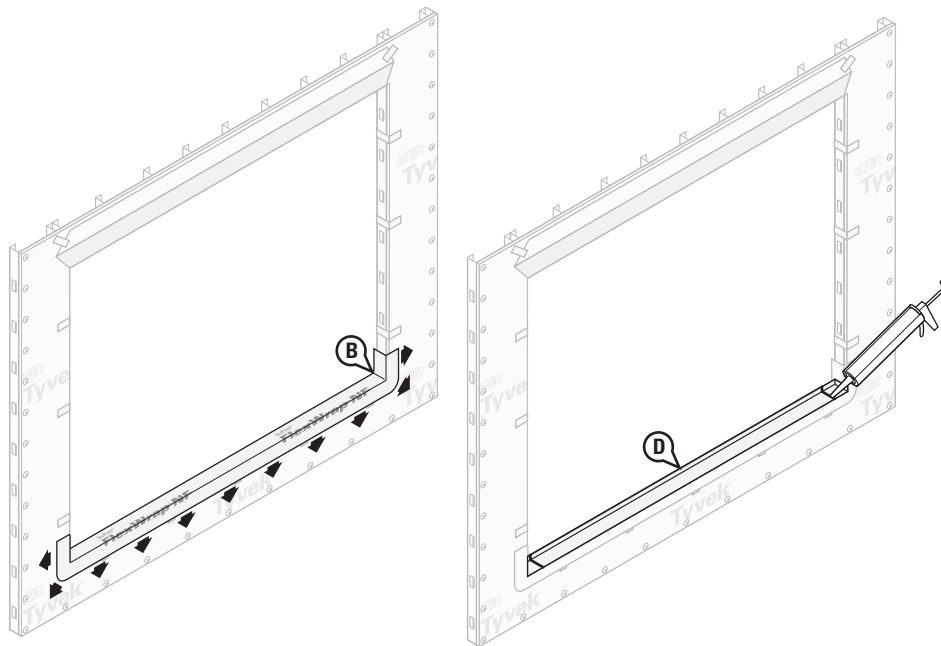

### STEP 8

- Wrap 9" DuPont™ StraightFlash™ into the rough opening at each jamb and onto wall face. The flashing should align with the interior edge of the jamb framing. Cut the jamb flashing the vertical length of the rough opening.
- Jamb flashing should be long enough to overlap the sill flashing by at least 2" and be overlapped by future head flashing by at least 2" .

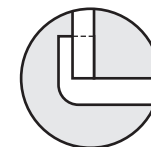
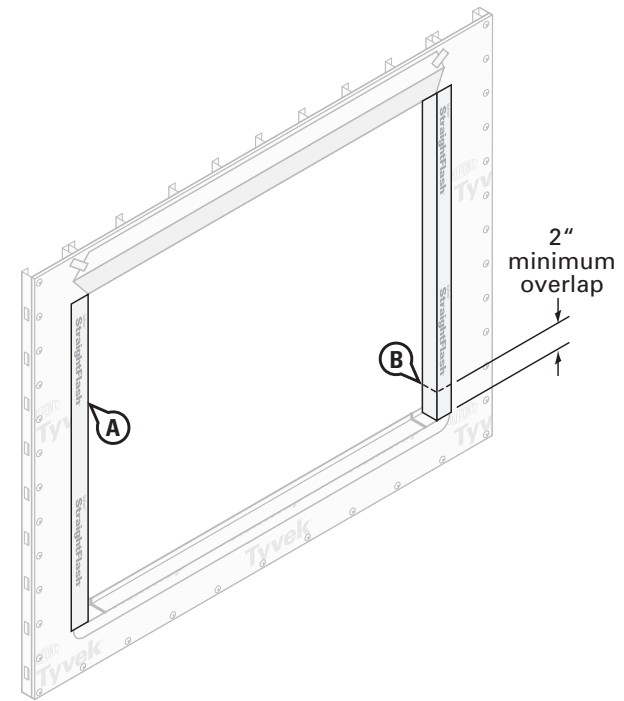

**INCORRECT**  
DuPont™ FlexWrap™ NF  
reverse flashed

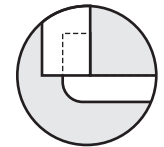

**CORRECT**  
DuPont™ StraightFlash™  
overlaps DuPont™  
FlexWrap™ NF

## DuPont Self-Adhered Flashing Systems Installation Guidelines

### STEP 9

A. Spray the top of the jambs and exposed sheathing with DuPont™ Adhesive/Primer.

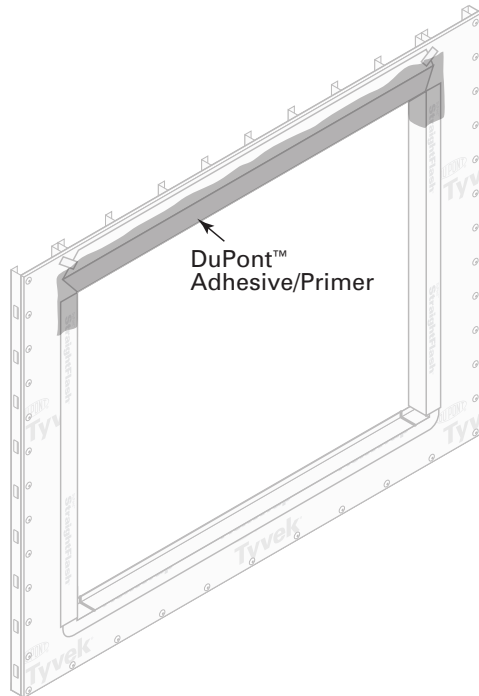

### STEP 10

A. Adhere DuPont™ FlexWrap™ NF to the head using the same installation process as shown in steps 6 and 7 for the sill flashing. Make sure the DuPont™ FlexWrap™ NF is cut long enough to overlap the jamb flashing by at least 2".

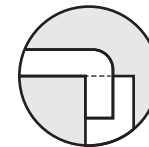
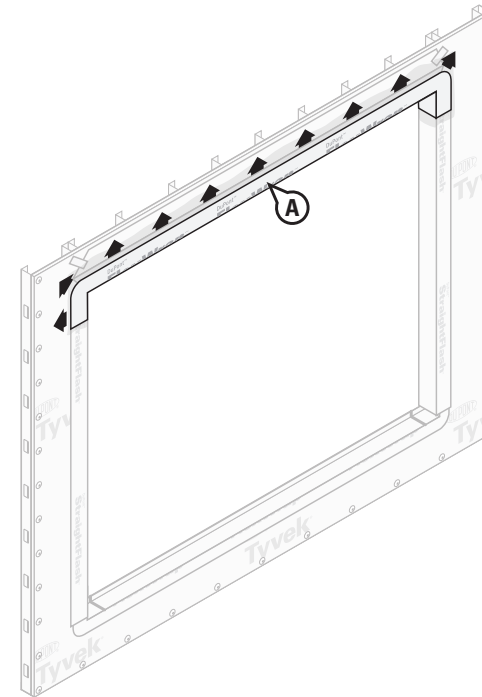

**INCORRECT**  
DuPont™ FlexWrap™ NF  
reverse flashed

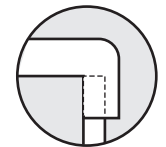

**CORRECT**  
DuPont™ StraightFlash™  
overlaps DuPont™  
FlexWrap™ NF



## DuPont Self-Adhered Flashing Systems Installation Guidelines

### STEP 11

- A. Install storefront window per manufacturer's installation instructions.
- B. Glaze windows per manufacturer's instructions.
- C. See pages 43-45 if optional skirt flashing is desired.

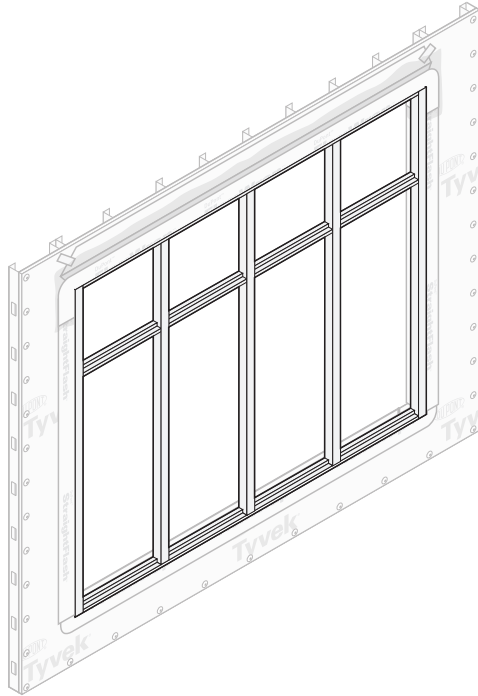

### STEP 12

- A. Flip down the head flap and **trim 1"-2" above the window opening**. Terminate flap along the top of the window with 3" DuPont™ Tyvek® Tape or 4" DuPont™ StraightFlash™. (See General Instructions for when 3" DuPont™ Tyvek® Tape is allowed).
- B. Apply 4" DuPont™ StraightFlash™ over the diagonal seams.
- C. Install remaining DuPont™ Tyvek® Wrap Cap Fasteners at head per the recommended spacing (every 12" to 18" depending on the vertical stud line).

**NOTE:** For high performance designs or areas of extreme exposure use 4" DuPont™ StraightFlash™ to seal the head flap and install additional mechanical fasteners through the flashing at the head flap and perimeter of window.

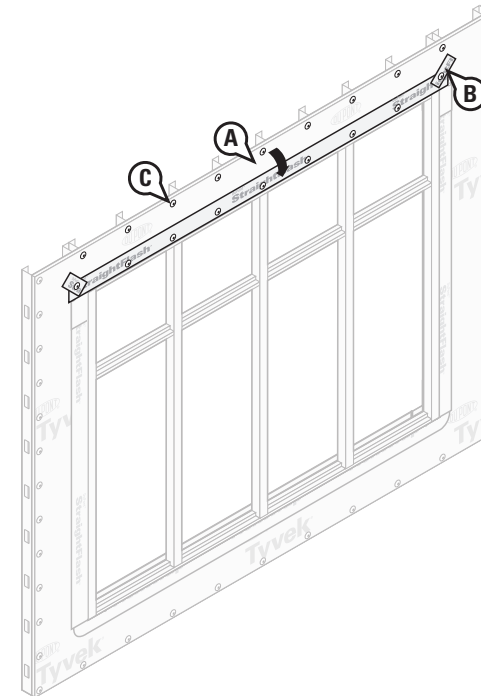

## DuPont Self-Adhered Flashing Systems Installation Guidelines

### STEP 13

#### Interior view

- A. Create a continuous perimeter seal using backer rod and sealant or DuPont™ Window and Door Foam on window interior to resist air and water infiltration.
- B. When the facade is complete, place a continuous sealant bead integrating the window to the facade.

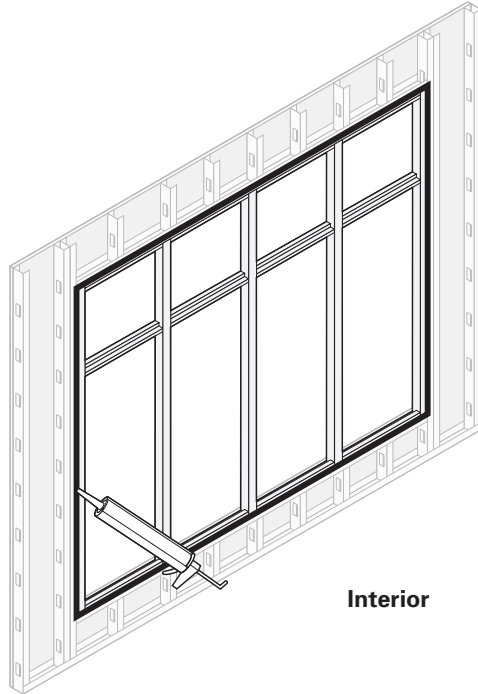

## DuPont Self-Adhered Flashing Systems Installation Guidelines

### Alternate Flanged Window Detail Aligned with FMA/AAMA 100-12 (Method A)

Method applies to following products:

- DuPont™ StraightFlash™
- DuPont™ FlexWrap™ NF
- DuPont™ Flashing Tape

#### STEP 1

A. Cut rough opening in sheathing for window. Ensure that sheathing is cut flush with, or slightly below the sill framing to allow for positive drainage.

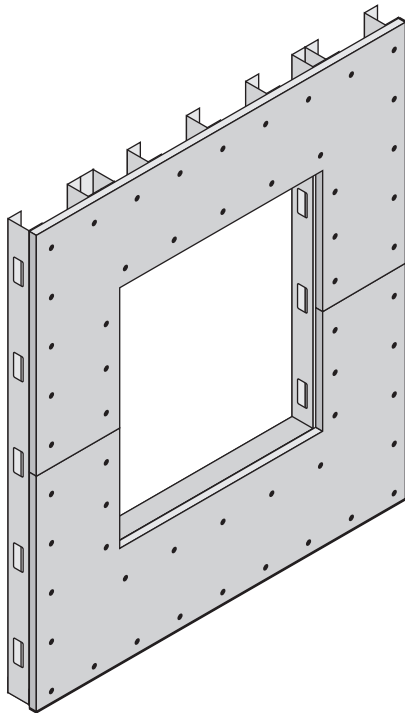

#### STEP 2

A. Wrap wall as shown in *DuPont™ Tyvek® Mechanically Fastened Air and Water Barrier Installation Guidelines for Buildings Greater Than 4 Stories* that can be found at [www.weatherization.tyvek.com](http://www.weatherization.tyvek.com). Do not install fasteners within 6" of the sills and jambs of the openings and within 9" of the head of the openings.

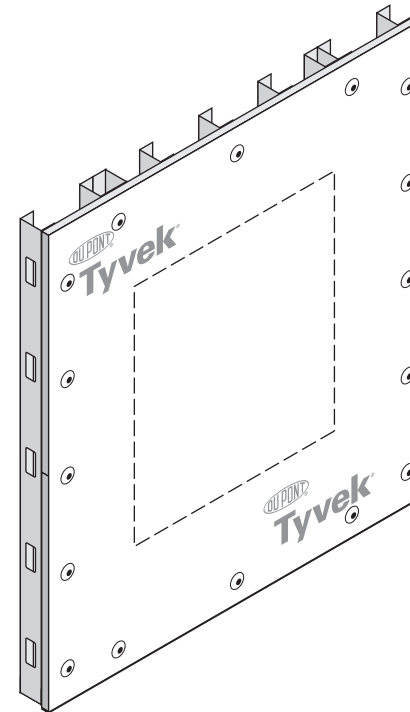

## DuPont Self-Adhered Flashing Systems Installation Guidelines

### STEP 3

Prepare air and water barrier for window installation.

- Cut an opening in the DuPont™ Tyvek® air and water barrier using a square cut around the perimeter of the rough opening.
- Cuts should be made along the dashed indicated lines. (Ensure that the DuPont™ Tyvek® air and water barrier is cut flush with the sheathing and is not wrapped into the rough opening.)
- Cut a head flap at a 45° angle to expose 8" of sheathing to allow for head flashing installation.

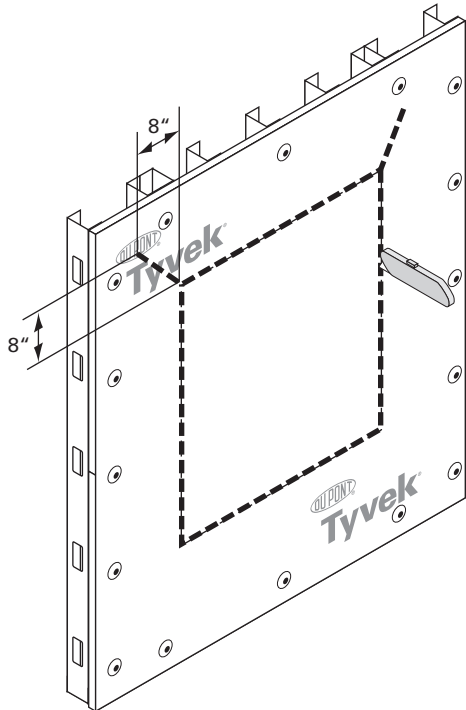

### STEP 4

- Flip the head flap up to expose the sheathing and temporarily secure with tape.
- Temporarily secure DuPont™ Tyvek® air and water barrier with DuPont™ Tyvek® Tape around rough opening before flashing is installed to help facilitate flashing installation.

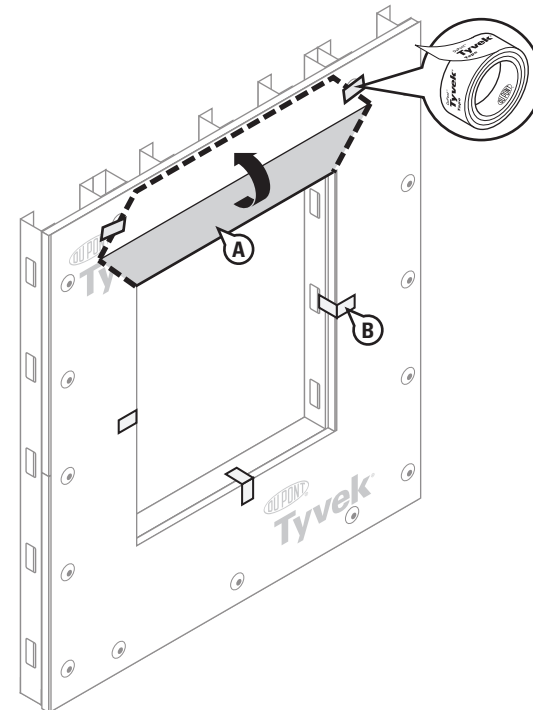

## DuPont Self-Adhered Flashing Systems Installation Guidelines

### STEP 5

- Prepare the sill flashing by cutting a piece of DuPont™ FlexWrap™ NF that is at least 12" longer than sill length. Use 6" DuPont™ FlexWrap™ NF for 2" x 4" framing and 9" DuPont™ FlexWrap™ NF for 2" x 6" framing.
- Inspect installation surface to ensure surface is free of dirt or substances that could interfere with adhesion as well as any sharp protrusions.

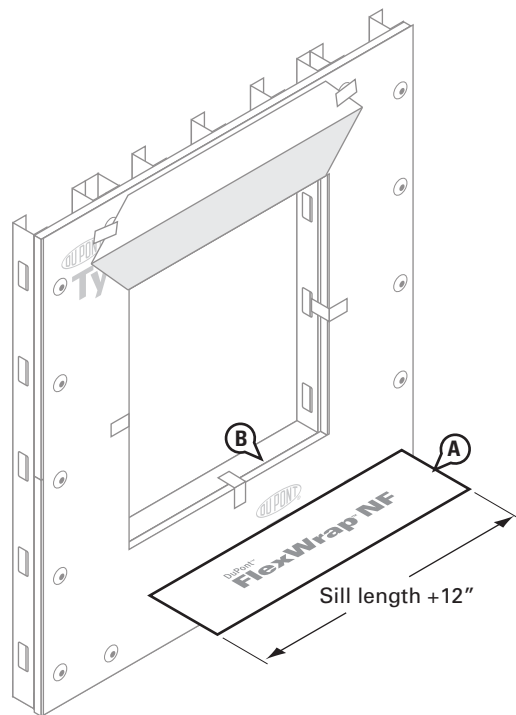

### STEP 6

- Install the sill flashing. Remove the largest strip of release paper, align the flashing with the interior edge of sill, and install into rough opening across sill and up jambs (min 6"). Apply working from the middle of the sill towards the sides. Secure DuPont™ FlexWrap™ NF tightly into the corners by first working in along the sill before adhering up the jambs.
- Cover holes in studs with patches of DuPont™ self-adhered flashing product.

**DO NOT STRETCH MATERIAL ALONG THE SILL OR JAMBS.**

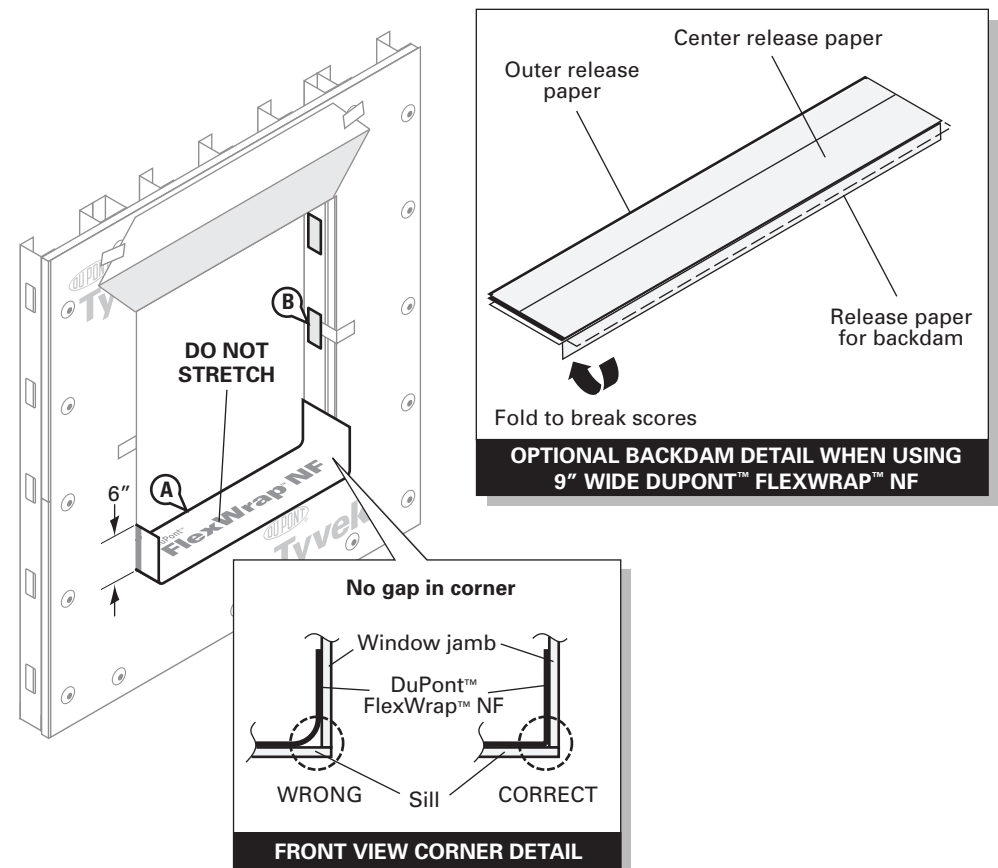

## DuPont Self-Adhered Flashing Systems Installation Guidelines

### STEP 7

- Remove second half of the release paper.
- Fan DuPont™ FlexWrap™ NF at bottom corners and adhere onto face of wall.
- Firmly press sill flashing to ensure full adhesion on all surfaces. Eliminate wrinkles and bubbles by smoothing surface and repositioning as necessary.

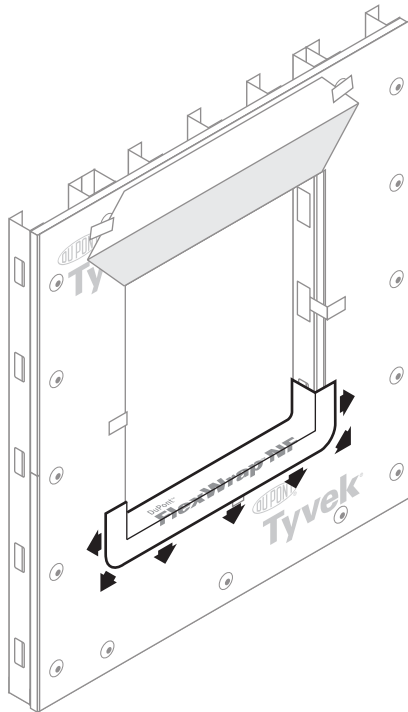

### STEP 8

- Install 4" DuPont™ StraightFlash™ into the rough opening at each jamb and onto wall face. The flashing does not need to align with the interior edge of the jamb framing. Cut the jamb flashing the vertical length of the rough opening.
- Jamb flashing should be long enough to overlap the sill flashing by at least 2" and be overlapped by future head flashing by at least 2".
- Apply sealant to inside corners of rough opening at jamb/head.

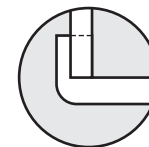
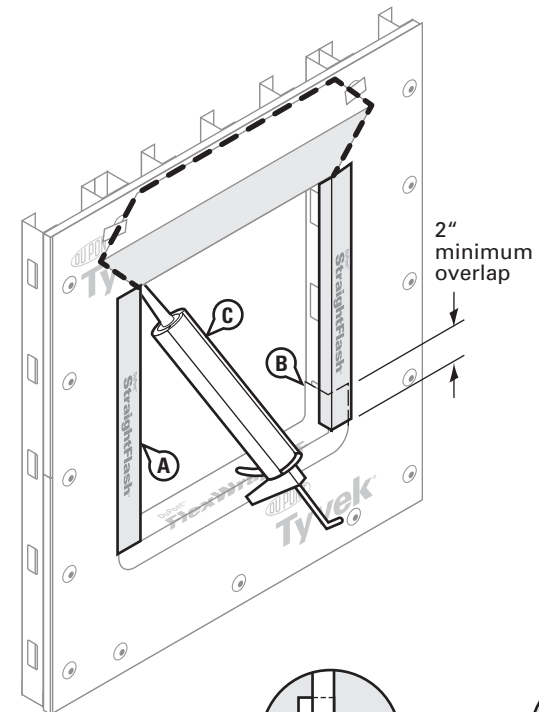

**INCORRECT**  
DuPont™ FlexWrap™ NF  
reverse flashed

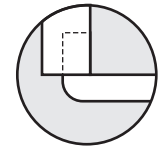

**CORRECT**  
DuPont™ StraightFlash™  
overlaps DuPont™  
FlexWrap™ NF

## DuPont Self-Adhered Flashing Systems Installation Guidelines

### STEP 9

A. Apply continuous bead of sealant at the window head and jambs to wall or back side of window mounting flange.

**DO NOT APPLY CONTINUOUS SEALANT BEAD ACROSS BOTTOM SILL FLANGE** to allow for drainage. If sealant is applied to the sill, ensure that there are at least two (2) 2" gaps in the sealant bead for every 4' of window to allow for drainage.

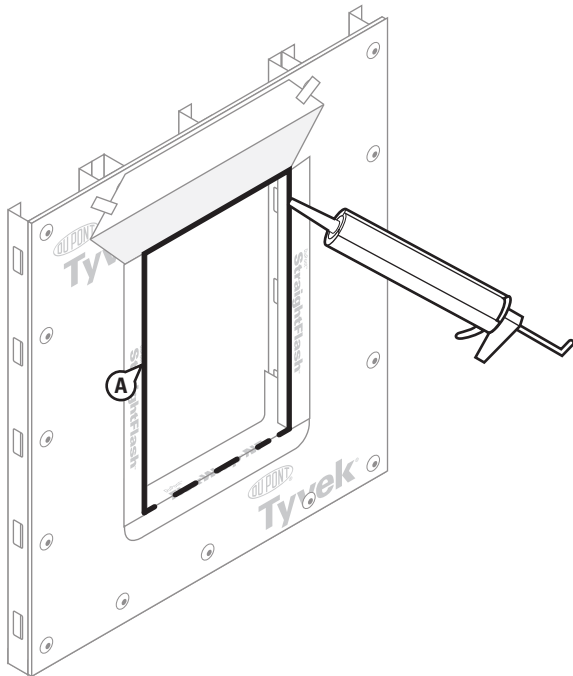

### STEP 10

A. Install window according to manufacturer's instructions.

B. Apply DuPont™ Adhesive/Primer to exposed sheathing.

C. Cut two pieces of DuPont™ StraightFlash™, DuPont™ Flashing Tape\* or DuPont™ FlexWrap™ NF for jamb flashing extending 1" above window head flange and 4" to 6" below bottom edge of sill flashing. Remove release paper and press tightly along sides of window frame.

D. Cut a piece of DuPont™ StraightFlash™, DuPont™ Flashing Tape\* or DuPont™ FlexWrap™ NF for head flashing, which extends beyond outer edges of jamb flashings. Remove release paper and install completely covering mounting flange and adhering to exposed sheathing or framing members.

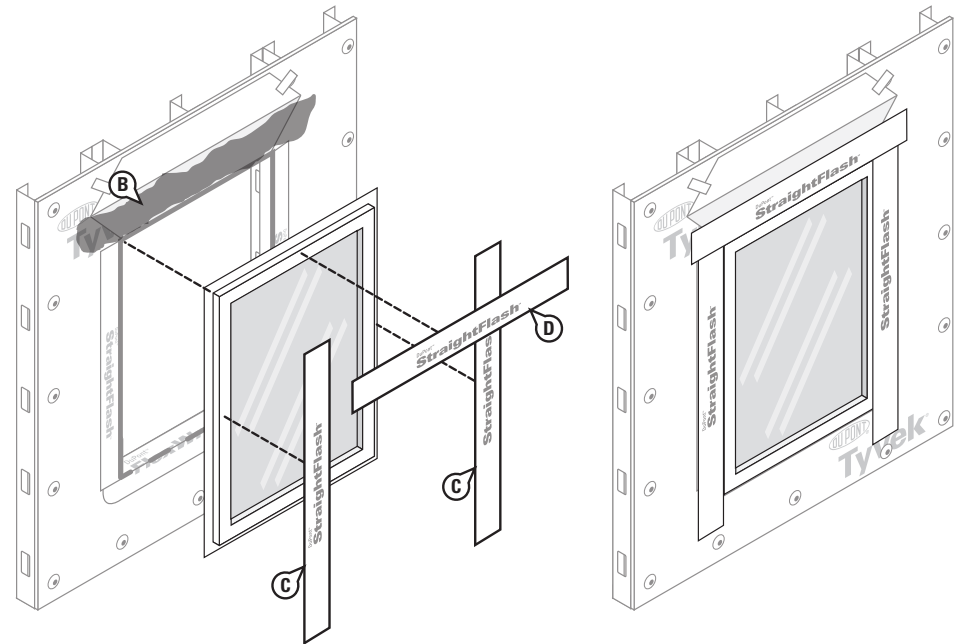

\*DuPont™ Flashing Tape is only permitted for Residential-Use building structures. Residential-Use (Group R) is defined by the 2015/2018 International Building Code.

## DuPont Self-Adhered Flashing Systems Installation Guidelines

### STEP 11

- A. Flip down upper flap of DuPont™ Tyvek® air and water barrier so it lays flat across head flashing, then **trim 1"-2" above the window opening**.
- B. Tape along all cuts in DuPont™ Tyvek® air and water barrier and tape across head of the window with 3" DuPont™ Tyvek® Tape, DuPont™ Flashing Tape\* or 4" DuPont™ StraightFlash™. (See General Instructions for when 3" DuPont™ Tyvek® Tape is allowed.)
- C. Install DuPont™ Tyvek® Wrap Cap Fasteners at appropriate spacing at head.

**NOTE:** For high performance designs or areas of extreme exposure use 4" DuPont™ StraightFlash™ to seal the head flap and install additional mechanical fasteners through the flashing at the head flap and perimeter of window.

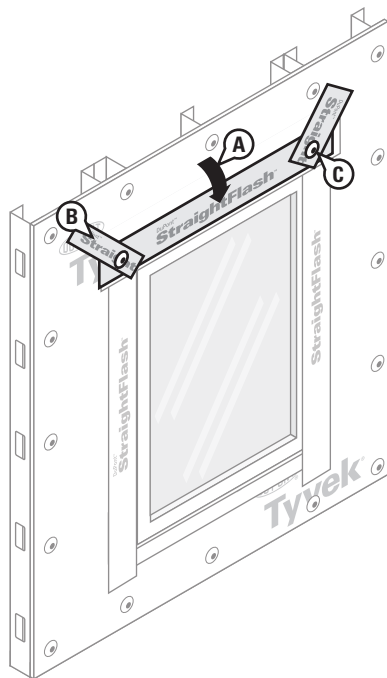

### STEP 12

Final Step

- A. Seal around the window opening at the interior with sealant (and backer rod as necessary) or DuPont™ Window and Door Foam. Sealant and backer rod, or foam, will also serve as a back dam.
- B. **OPTIONAL:** If back dam is desired use alternate back dam. Install retention clips around the window to permanently secure it in the rough opening as recommended by window manufacturer to complete installation.

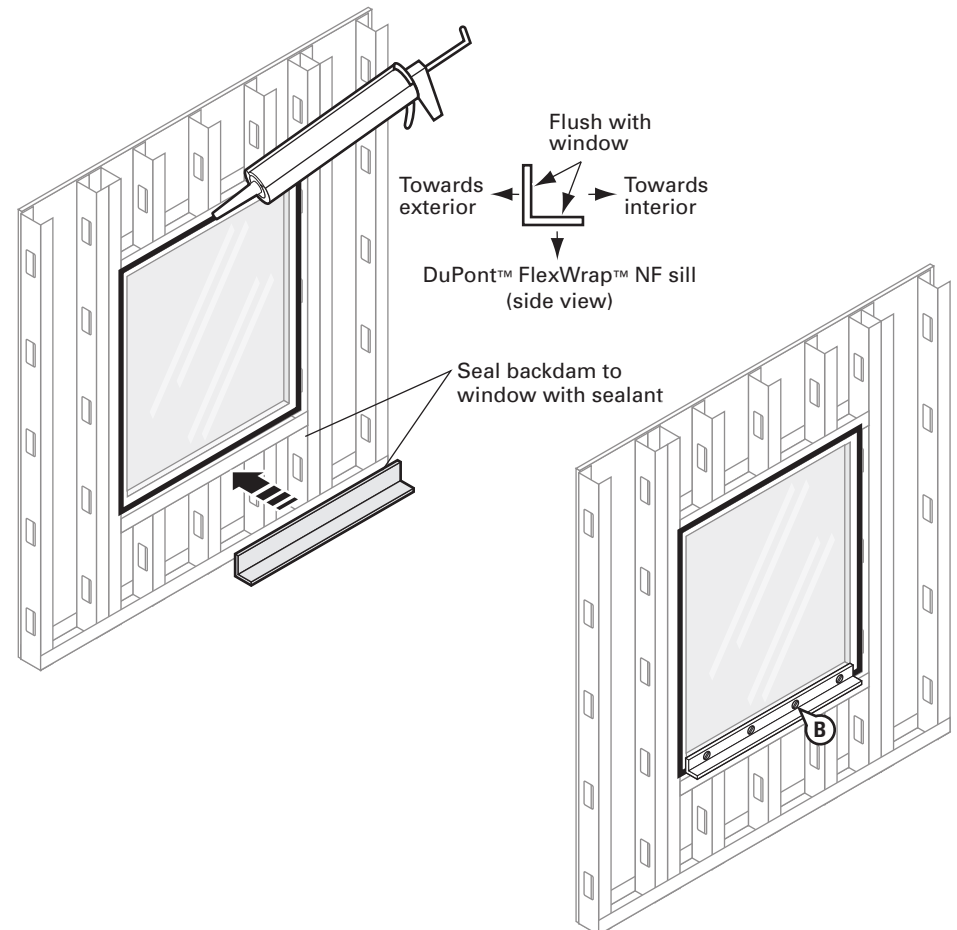

\*DuPont™ Flashing Tape is only permitted for Residential-Use building structures. Residential-Use (Group R) is defined by the 2015/2018 International Building Code.



## DuPont Self-Adhered Flashing Systems Installation Guidelines

### Alternate Flanged Window Detail Aligned with FMA/AAMA 100-12 (Method B)

Method applies to following products:

- DuPont™ StraightFlash™
- DuPont™ FlexWrap™ NF
- DuPont™ Flashing Tape

#### STEP 1

A. Cut rough opening in sheathing for window. Ensure that sheathing is cut flush with, or slightly below the sill framing to allow for positive drainage.

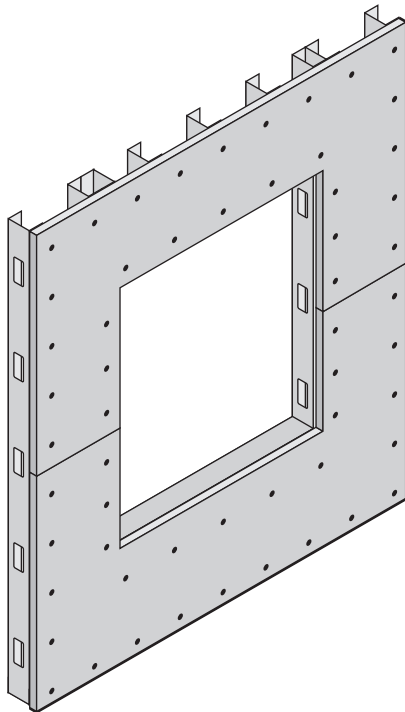

#### STEP 2

A. Wrap wall as shown in *DuPont™ Tyvek® Mechanically Fastened Air and Water Barrier Installation Guidelines for Buildings Greater Than 4 Stories* that can be found at [www.weatherization.tyvek.com](http://www.weatherization.tyvek.com). Do not install fasteners within 6" of the sills and jambs of the openings and within 9" of the head of the openings.

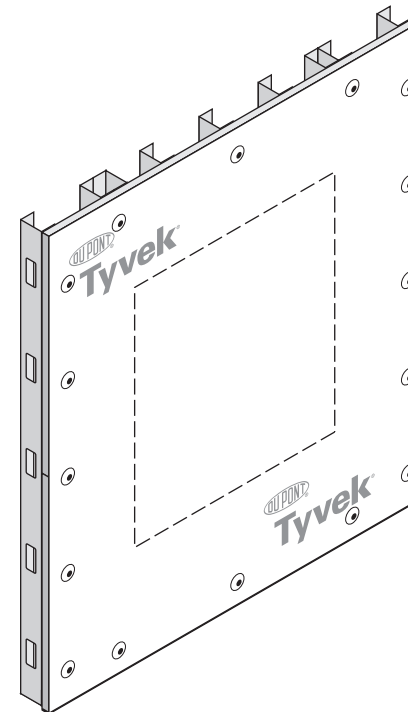

## DuPont Self-Adhered Flashing Systems Installation Guidelines

### STEP 3

Prepare air and water barrier for window installation.

- Cut an opening in the DuPont™ Tyvek® air and water barrier using a square cut around the perimeter of the rough opening.
- Cuts should be made along the dashed indicated lines. (Ensure that the DuPont™ Tyvek® air and water barrier is cut flush with the sheathing and is not wrapped into the rough opening.)
- Cut a head flap at a 45° angle to expose 8" of sheathing to allow for head flashing installation.
- Flip the head flap up to expose the sheathing and temporarily secure with DuPont™ Tyvek® Tape.

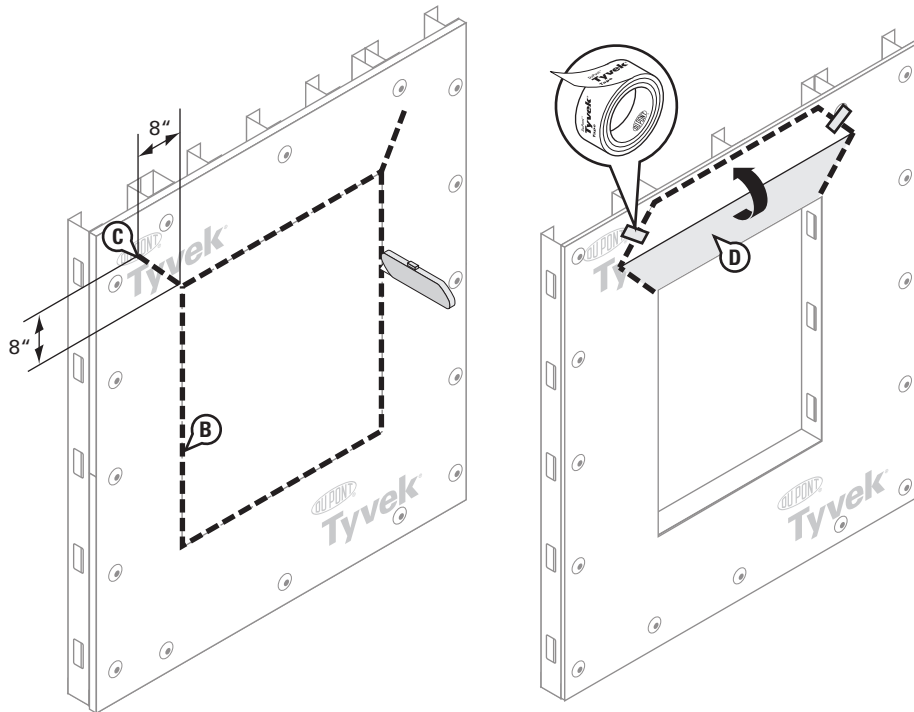

### STEP 4

- Cut two 45° slits extending from the bottom corner up and away from the window opening to expose approximately 8" of sheathing. This will create a flap at each jamb to allow for jamb flashing installation.
- Flip the flaps to the side to expose the sheathing and temporarily secure with DuPont™ Tyvek® Tape.

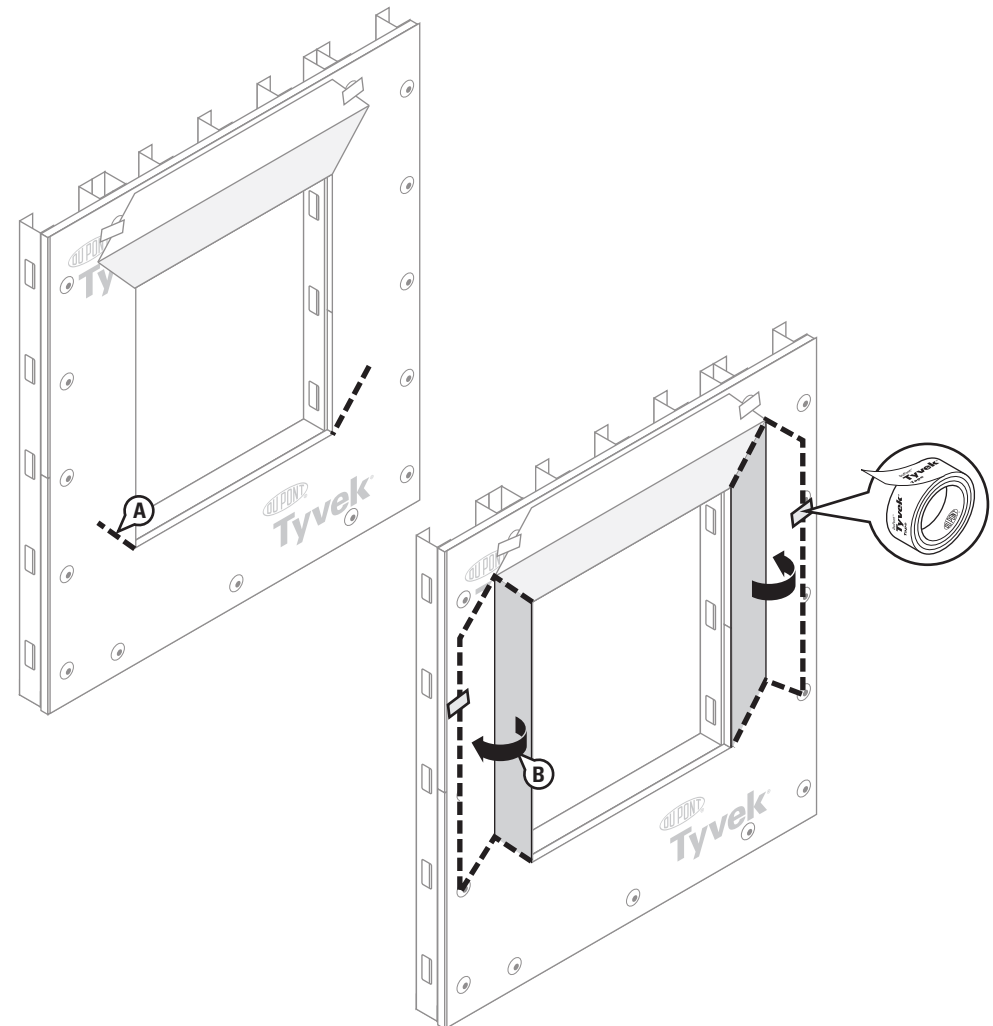

## DuPont Self-Adhered Flashing Systems Installation Guidelines

### STEP 5

- Apply DuPont™ Adhesive/Primer to exposed sheathing at jambs and head.
- Prepare the sill flashing by cutting a piece of DuPont™ FlexWrap™ NF that is at least 12" longer than sill length. Use 6" DuPont™ FlexWrap™ NF for 2" x 4" framing and 9" DuPont™ FlexWrap™ NF for 2" x 6" framing.
- Inspect installation surface to ensure surface is free of dirt or substances that could interfere with adhesion as well as any sharp protrusions.

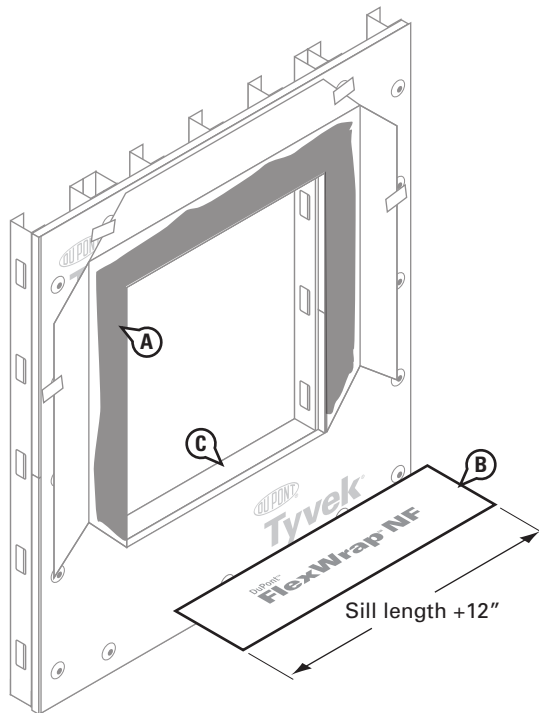

### STEP 6

- Install the sill flashing. Remove the largest strip of release paper, align the flashing with the interior edge of sill, and install into rough opening across sill and up jambs (min 6"). Apply working from the middle of the sill towards the sides. Secure DuPont™ FlexWrap™ NF tightly into the corners by first working in along the sill before adhering up the jambs.
- Cover holes in studs with patches of DuPont™ self-adhered flashing product.

**DO NOT STRETCH MATERIAL ALONG THE SILL OR JAMBS.**

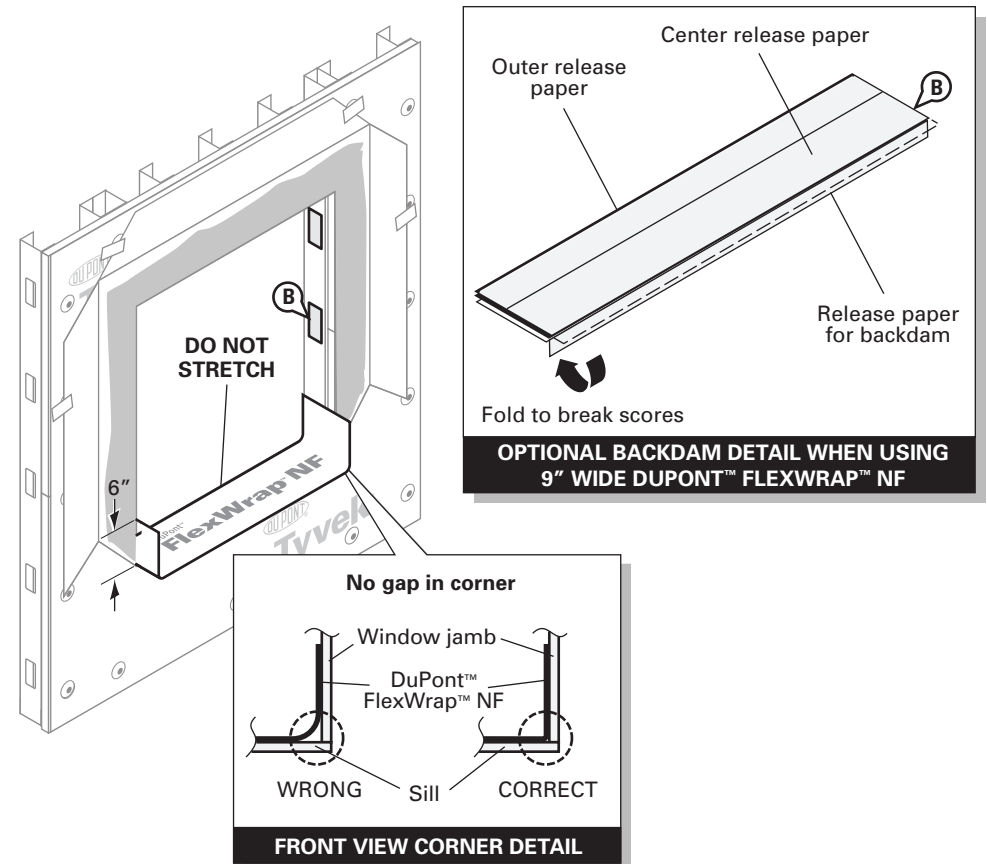

## DuPont Self-Adhered Flashing Systems Installation Guidelines

### STEP 7

- Remove second half of the release paper.
- Fan DuPont™ FlexWrap™ NF at bottom corners and adhere onto face of wall.
- Firmly press sill flashing to ensure full adhesion on all surfaces. Eliminate wrinkles and bubbles by smoothing surface and repositioning as necessary.

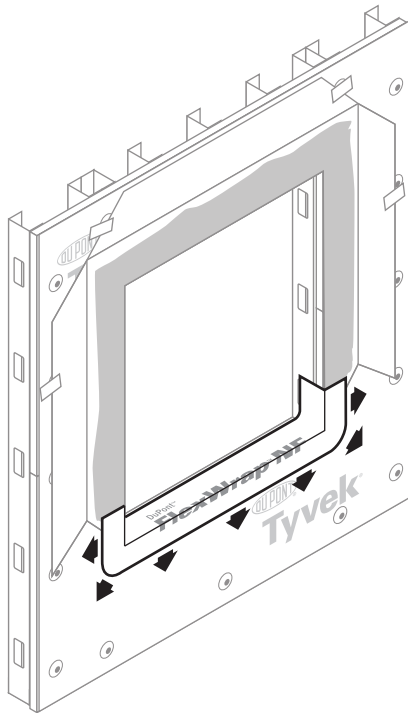

### STEP 8

- Apply continuous bead of sealant at the window head and jambs to wall or back side of window mounting flange.  
**DO NOT APPLY CONTINUOUS SEALANT BEAD ACROSS BOTTOM SILL FLANGE** to allow for drainage. If sealant is applied to the sill, ensure that there are at least two (2) 2" gaps in the sealant bead for every 4' of window to allow for drainage.

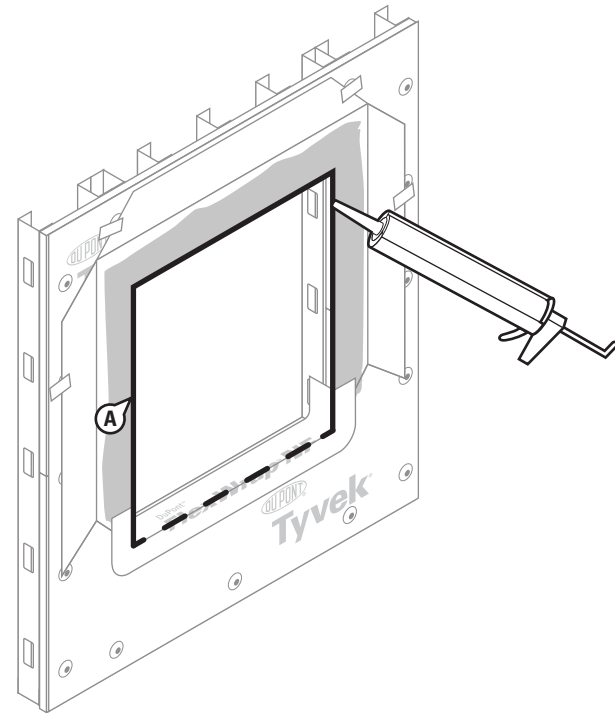

## DuPont Self-Adhered Flashing Systems Installation Guidelines

### For rectangular windows

#### STEP 9

- Install window according to manufacturer's instructions.
- Cut two pieces of DuPont™ StraightFlash™, DuPont™ Flashing Tape\* or DuPont™ FlexWrap™ NF for jamb flashing extending 1" above window head flange and 4" to 6" below bottom edge of sill flashing. Remove release paper and press tightly along sides of window frame.
- Cut a piece of DuPont™ StraightFlash™, DuPont™ Flashing Tape\* or DuPont™ FlexWrap™ NF for head flashing, which extends beyond outer edges of jamb flashings. Remove release paper and install completely covering mounting flange and adhering to exposed sheathing or framing members.

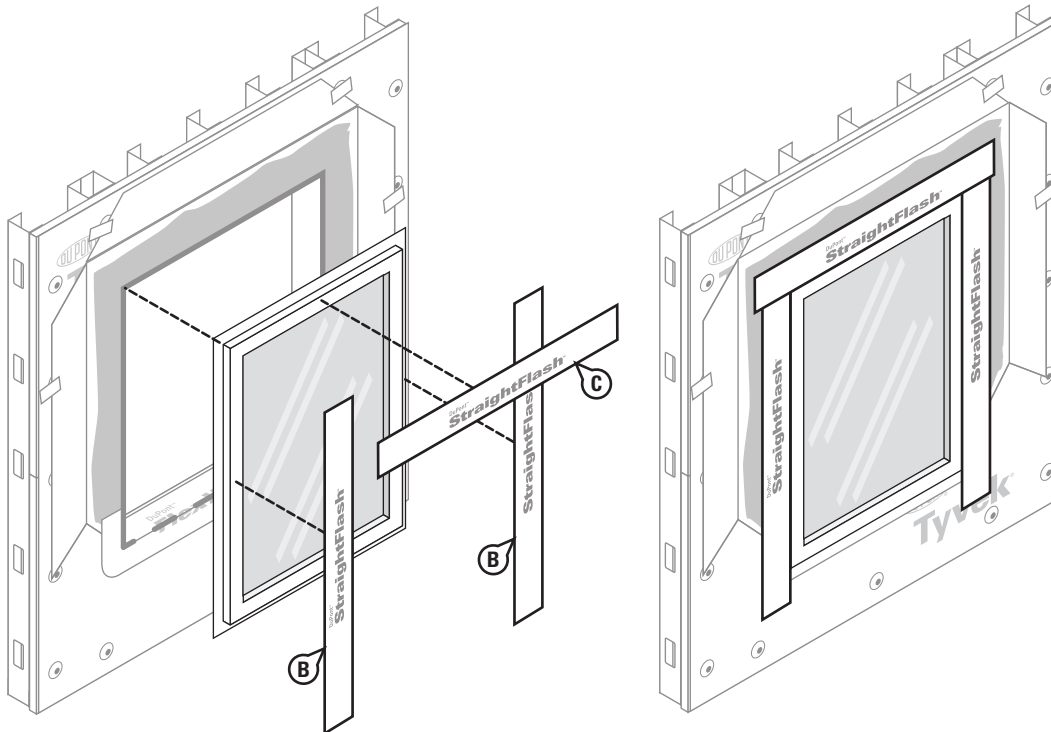

#### STEP 10

- Flip over flaps of DuPont™ Tyvek® air and water barrier so each lays flat across jamb flashing, then **trim 1"-2" from the window opening** using shears so as not to damage the DuPont™ StraightFlash™ below.
- Starting at the bottom of the window, install DuPont™ Flashing Tape\* or 4" DuPont™ StraightFlash™ along the angled cut in in the DuPont™ Tyvek® air and water barrier. (See General Instructions for when 3" DuPont™ Tyvek® Tape is allowed.)
- Install DuPont™ Flashing Tape\* or 4" DuPont™ StraightFlash™ along the jamb flaps. Repeat on other side of window.

**NOTE:** For high performance designs or areas of extreme exposure use 4" DuPont™ StraightFlash™ to seal the head flap and install additional mechanical fasteners through the flashing at the jamb flap and perimeter of window.

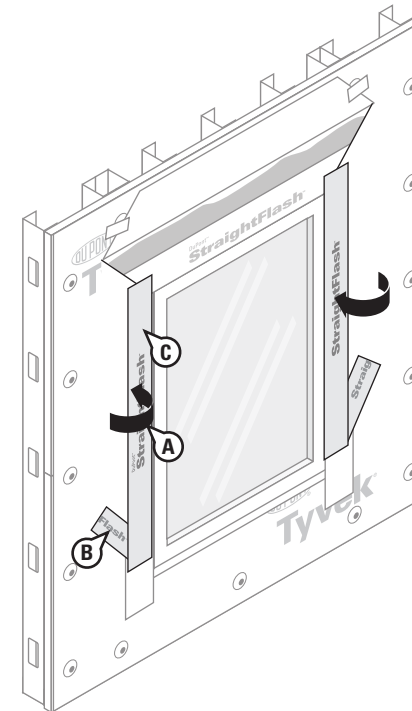

\*DuPont™ Flashing Tape is only permitted for Residential-Use building structures. Residential-Use (Group R) is defined by the 2015/2018 International Building Code.

## DuPont Self-Adhered Flashing Systems Installation Guidelines

### STEP 11

- A. Flip down upper flap of DuPont™ Tyvek® air and water barrier so it lays flat across head flashing, then **trim 1"-2" above the window opening**.
- B. Tape along all cuts in DuPont™ Tyvek® air and water barrier and tape across head of the window with 3" DuPont™ Tyvek® Tape, DuPont™ Flashing Tape\* or 4" DuPont™ StraightFlash™. (See General Instructions for when 3" DuPont™ Tyvek® Tape is allowed.)
- C. Install DuPont™ Tyvek® Wrap Cap Fasteners at appropriate spacing at head.

**NOTE:** For high performance designs or areas of extreme exposure use 4" DuPont™ StraightFlash™ to seal the head flap and install additional mechanical fasteners through the flashing at the head flap and perimeter of window.

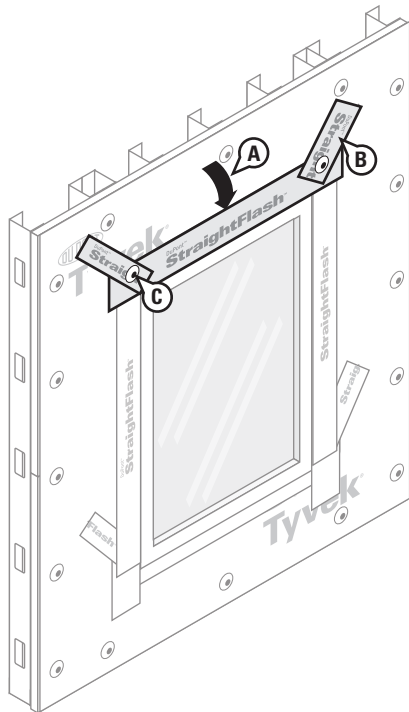

### STEP 12

Final Step

- A. Seal around the window opening at the interior with sealant (and backer rod as necessary) or DuPont™ Window and Door Foam. Sealant and backer rod, or foam, will also serve as a back dam.
- B. **OPTIONAL:** If back dam is desired use alternate back dam. Install retention clips around the window to permanently secure it in the rough opening as recommended by window manufacturer to complete installation.

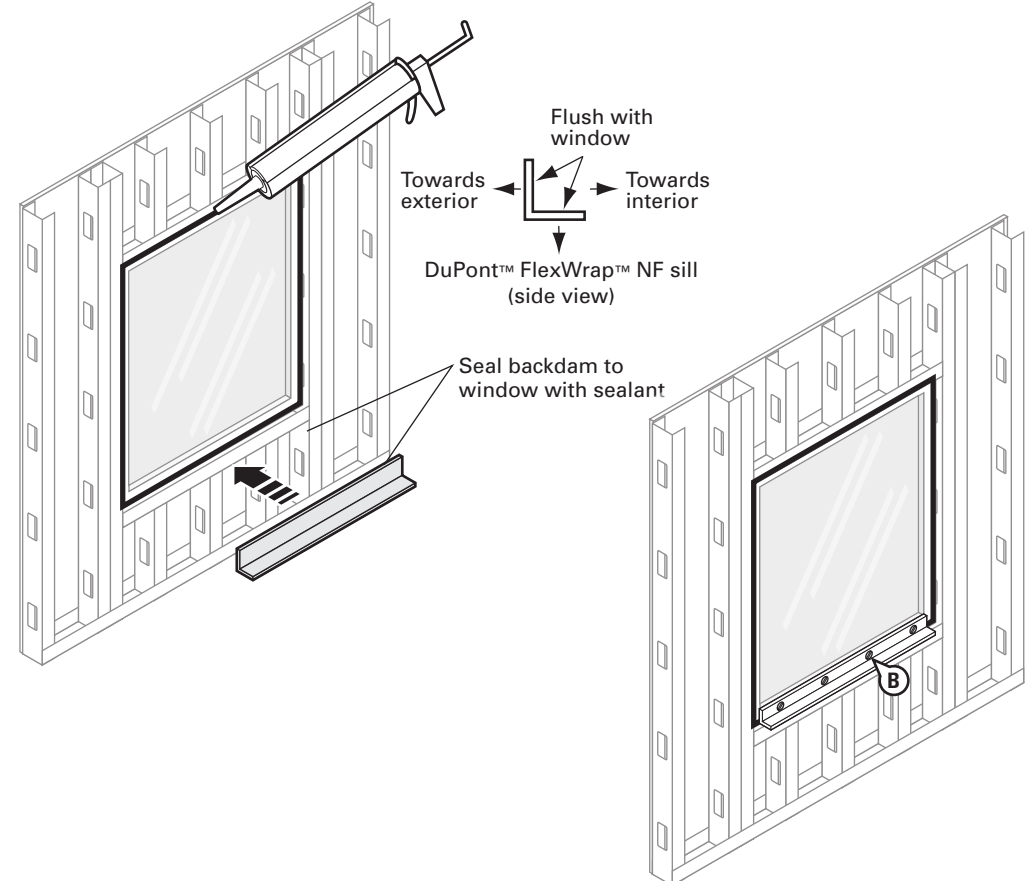

\*DuPont™ Flashing Tape is only permitted for Residential-Use building structures. Residential-Use (Group R) is defined by the 2015/2018 International Building Code.

## DuPont Self-Adhered Flashing Systems Installation Guidelines

### Alternate Flanged Window Detail Aligned with FMA/AAMA 100-12 (Method C)

Method applies to following products:

- DuPont™ StraightFlash™
- DuPont™ FlexWrap™ NF
- DuPont™ Flashing Tape

#### STEP 1

A. Cut rough opening in sheathing for window. Ensure that sheathing is cut flush with, or slightly below the sill framing to allow for positive drainage.

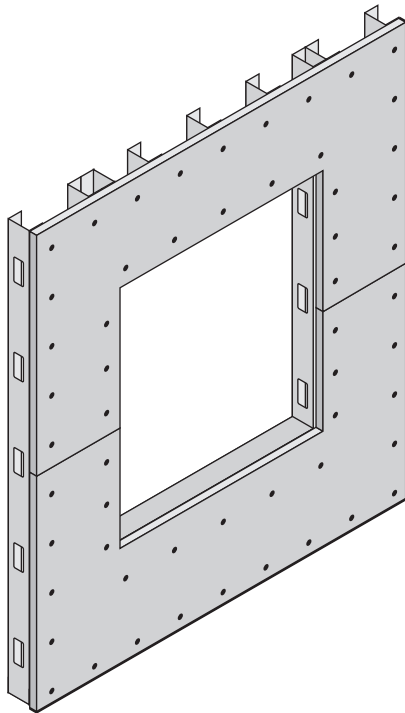

#### STEP 2

A. Wrap wall as shown in *DuPont™ Tyvek® Mechanically Fastened Air and Water Barrier Installation Guidelines for Buildings Greater Than 4 Stories* that can be found at [www.weatherization.tyvek.com](http://www.weatherization.tyvek.com). Do not install fasteners within 6" of the sills and jambs of the openings and within 9" of the head of the openings.

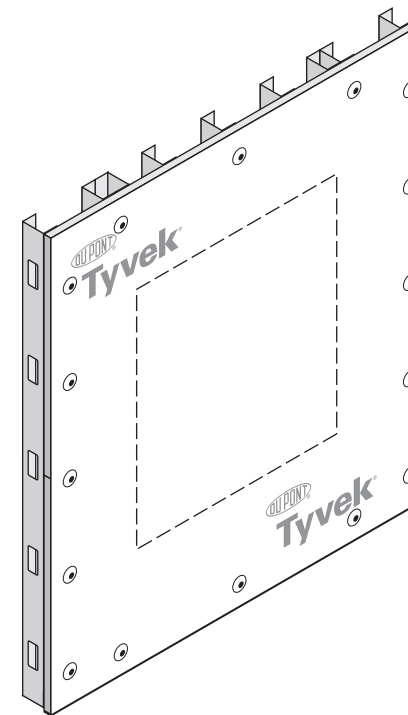

## DuPont Self-Adhered Flashing Systems Installation Guidelines

### STEP 3

Prepare air and water barrier for window installation.

- Make an "I-Cut" in the DuPont™ Tyvek® air and water barrier. For an "I-Cut" begin with a horizontal cut across the bottom and the top of the window frame (for round top windows, cut from the center cut straight down to the sill).
- Cut a head flap at a 45° angle to expose 8" of sheathing to allow for head flashing installation.
- Cut two 45° slits extending from the bottom corner up and away from the window opening to expose 6"-8" of sheathing. This will create a flap at each jamb to allow for jamb flashing installation.

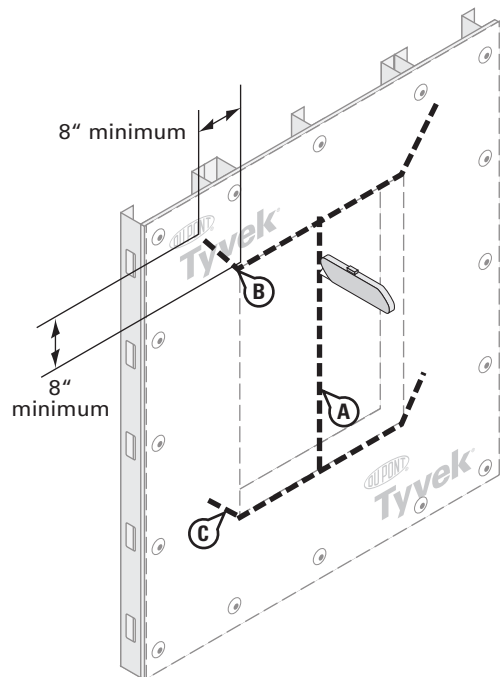

### STEP 4

- Flip the head flap up to expose the sheathing and temporarily secure with DuPont™ Tyvek® Tape.
- Flip the flaps to the side to expose the sheathing and temporarily secure with DuPont™ Tyvek® Tape.

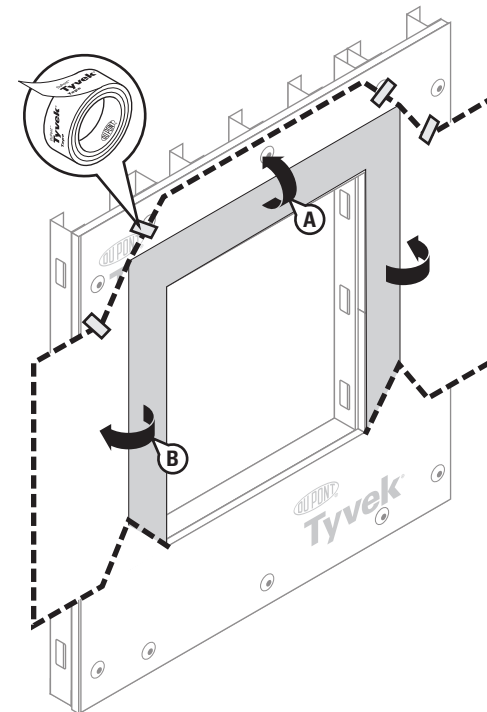



## DuPont Self-Adhered Flashing Systems Installation Guidelines

### STEP 5

- Prepare the sill flashing by cutting a piece of DuPont™ FlexWrap™ NF that is at least 12" longer than sill length. Use 6" DuPont™ FlexWrap™ NF for 2" x 4" framing and 9" DuPont™ FlexWrap™ NF for 2" x 6" framing.
- Inspect installation surface to ensure surface is free of dirt or substances that could interfere with adhesion as well as any sharp protrusions.
- Starting at the bottom corner, apply DuPont™ Adhesive/Primer to exposed sheathing at least 6" up the jamb.

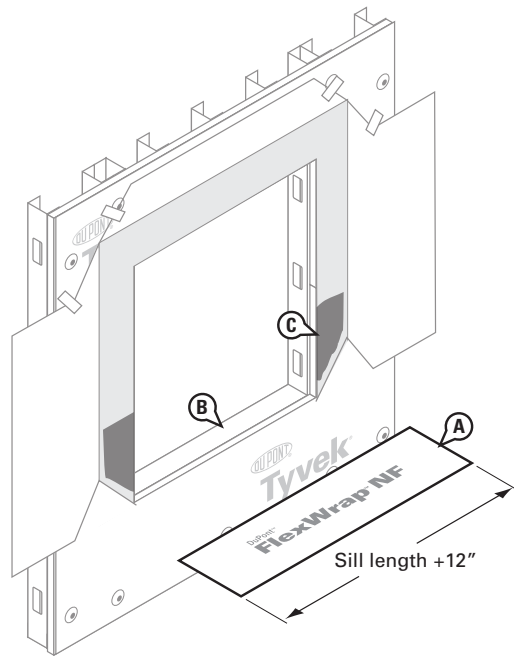

### STEP 6

- Install the sill flashing. Remove the largest strip of release paper, align the flashing with the interior edge of sill, and install into rough opening across sill and up jambs (min 6"). Apply working from the middle of the sill towards the sides. Secure DuPont™ FlexWrap™ NF tightly into the corners by first working in along the sill before adhering up the jambs.

**DO NOT STRETCH MATERIAL ALONG THE SILL OR JAMBS.**

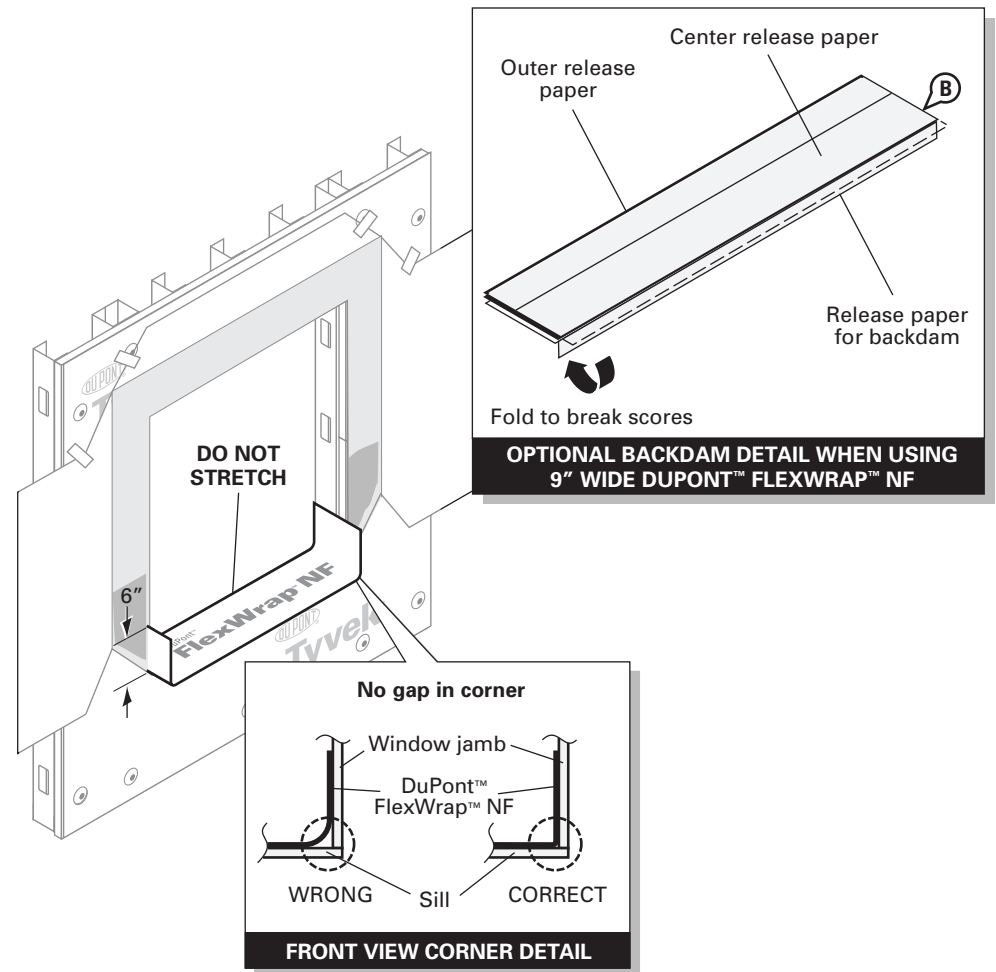

## DuPont Self-Adhered Flashing Systems Installation Guidelines

### STEP 7

- A. Remove second half of the release paper.
- B. Fan DuPont™ FlexWrap™ NF at bottom corners and adhere onto face of wall.
- C. Firmly press sill flashing to ensure full adhesion on all surfaces. Eliminate wrinkles and bubbles by smoothing surface and repositioning as necessary.
- D. Apply continuous bead of sealant to wall at the window jambs.

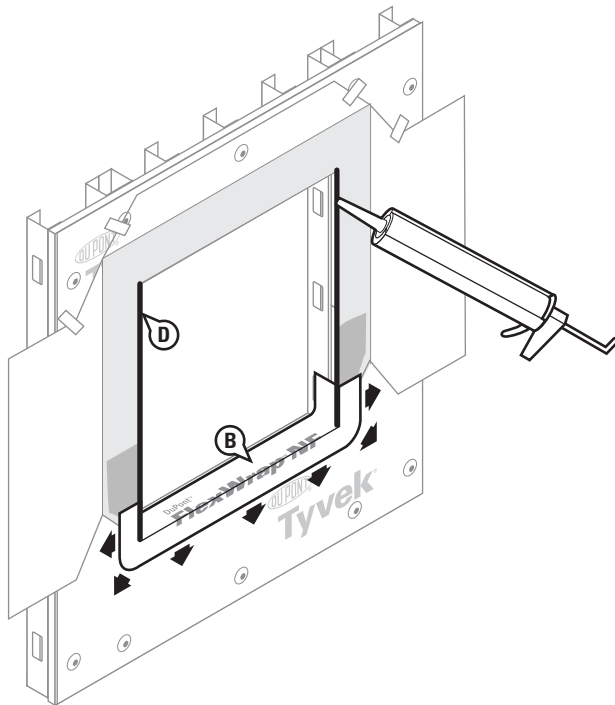

### STEP 8

- A. Fold side flaps into rough opening, cut excess flaps, and secure with 3" DuPont™ Tyvek® Tape, DuPont™ Flashing Tape\* or 4" DuPont™ StraightFlash™.

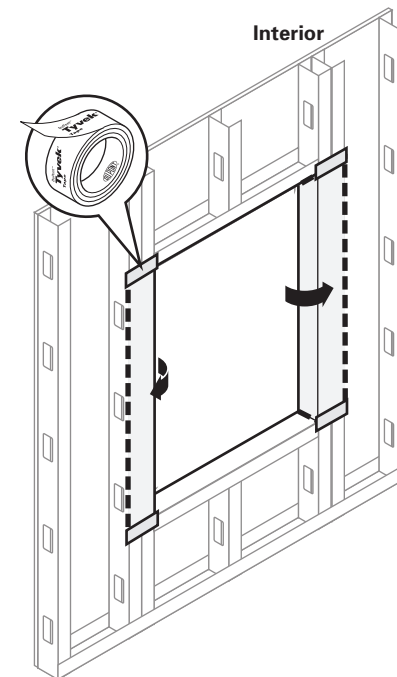

\*DuPont™ Flashing Tape is only permitted for Residential-Use building structures. Residential-Use (Group R) is defined by the 2015/2018 International Building Code.

## DuPont Self-Adhered Flashing Systems Installation Guidelines

### STEP 9

- A. Starting at the bottom of the window, install DuPont™ Flashing Tape\* or 4" DuPont™ StraightFlash™ along the angled cut in in the DuPont™ Tyvek® air and water barrier. (See General Instructions for when 3" DuPont™ Tyvek® Tape is allowed.)
- B. Apply continuous bead of sealant at the window head and jambs to wall or back side of window mounting flange. **DO NOT APPLY CONTINUOUS SEALANT BEAD ACROSS BOTTOM SILL FLANGE** to allow for drainage. If sealant is applied to the sill, ensure that there are at least two (2) 2" gaps in the sealant bead for every 4' of window to allow for drainage.

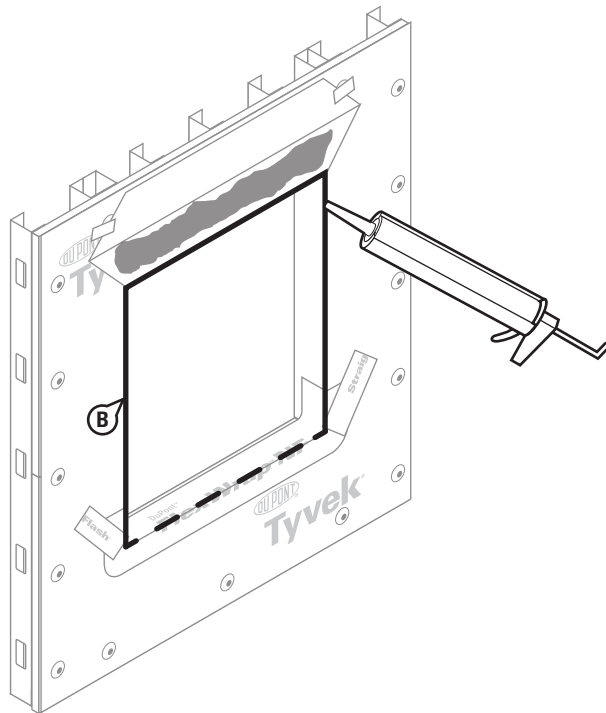

### STEP 10

- A. Install window according to manufacturer's instructions.
- B. Apply DuPont™ Adhesive/Primer to exposed sheathing at jambs and head.
- C. Cut two pieces of DuPont™ StraightFlash™, DuPont™ Flashing Tape\* or DuPont™ FlexWrap™ NF for jamb flashing extending 1" above window head flange and 4" to 6" below bottom edge of sill flashing. Remove release paper and press tightly along sides of window frame.
- D. Cut a piece of DuPont™ StraightFlash™, DuPont™ Flashing Tape\* or DuPont™ FlexWrap™ NF for head flashing, which extends beyond outer edges of jamb flashings. Remove release paper and install completely covering mounting flange and adhering to exposed sheathing or framing members.

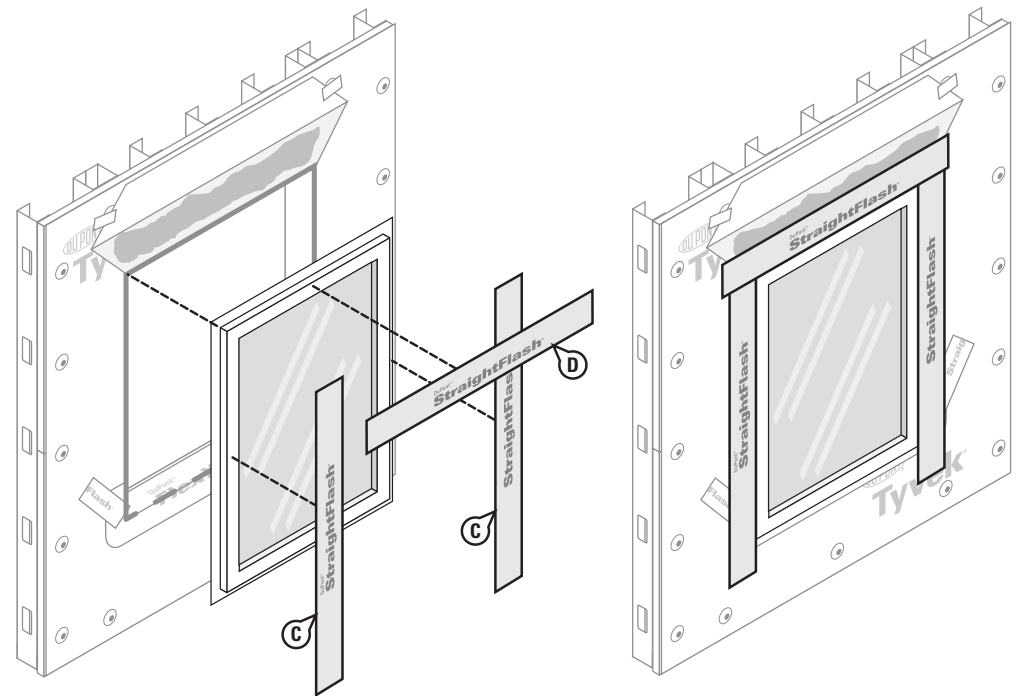

\*DuPont™ Flashing Tape is only permitted for Residential-Use building structures. Residential-Use (Group R) is defined by the 2015/2018 International Building Code.

## DuPont Self-Adhered Flashing Systems Installation Guidelines

### STEP 11

- Flip down upper flap of DuPont™ Tyvek® air and water barrier so it lays flat across head flashing, then **trim 1"-2" above the window opening**.
- Tape along all cuts in DuPont™ Tyvek® air and water barrier and tape across head of the window with 3" DuPont™ Tyvek® Tape, DuPont™ Flashing Tape\* or 4" DuPont™ StraightFlash™. (See General Instructions for when 3" DuPont™ Tyvek® Tape is allowed.)
- Install DuPont™ Tyvek® Wrap Cap Fasteners at appropriate spacing at head.

**NOTE:** For high performance designs or areas of extreme exposure use 4" DuPont™ StraightFlash™ to seal the head flap and install additional mechanical fasteners through the flashing at the head flap and perimeter of window.

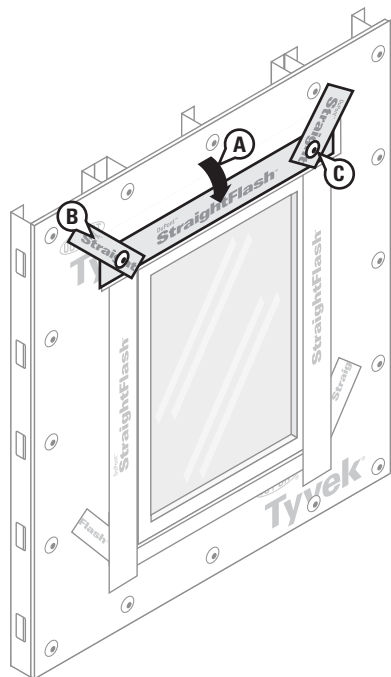

### STEP 12

Final Step

- Seal around the window opening at the interior with sealant (and backer rod as necessary) or DuPont™ Window and Door Foam. Sealant and backer rod, or foam, will also serve as a back dam.
- OPTIONAL:** If back dam is desired use alternate back dam. Install retention clips around the window to permanently secure it in the rough opening as recommended by window manufacturer to complete installation.

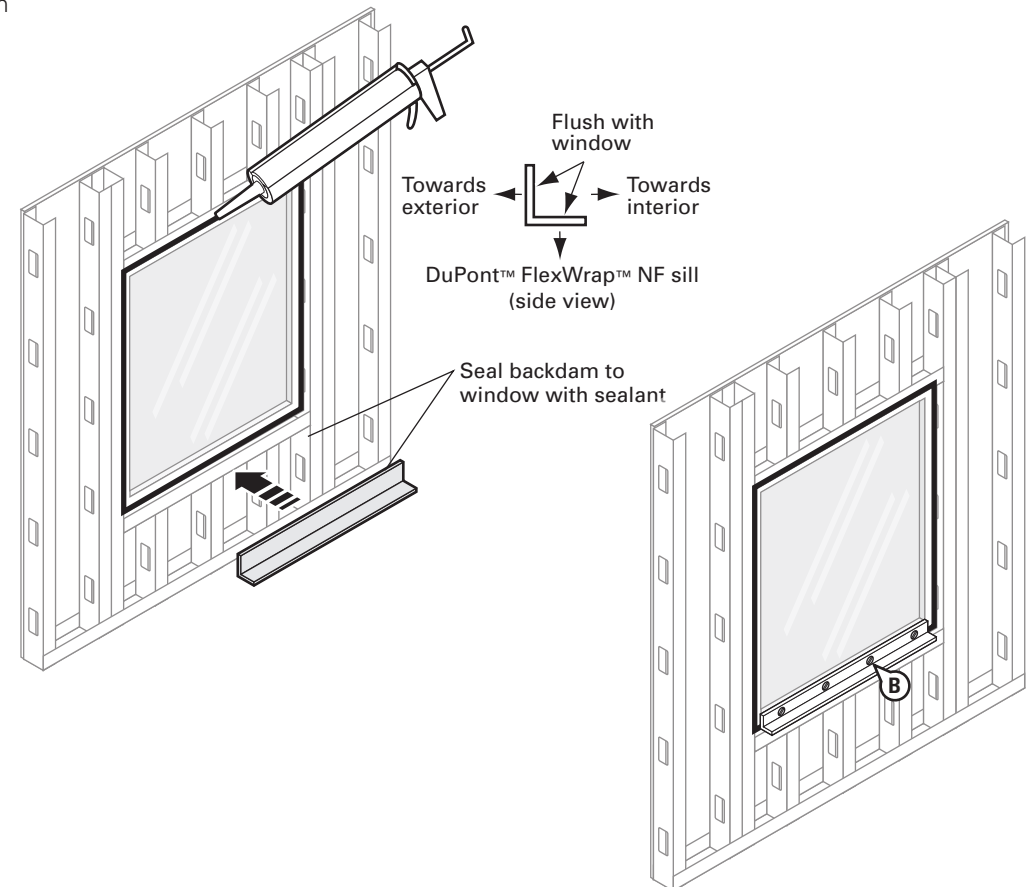

\*DuPont™ Flashing Tape is only permitted for Residential-Use building structures. Residential-Use (Group R) is defined by the 2015 International Building Code.

## Installation Instructions for Through Wall Flashing

### Through Wall Flashing – DuPont™ Tyvek® Interface

#### Base of wall

- Install through wall flashing on the vertical wall per plans and specifications. The through wall flashing may be terminated by using a reglet, counterflashing, termination bar or by embedding in a mortar joint.
- Overlap through wall flashing with DuPont™ Tyvek® air and water barrier by 6".
- Mechanically fasten bottom of air and water barrier through top of through wall flashing.
- Seal vertical and horizontal seams using 3" DuPont™ Tyvek® Tape or DuPont™ self-adhered flashing products.

**NOTE:** For high performance designs or areas of extreme exposure install additional mechanical fasteners through the DuPont™ Tyvek® air and water barrier terminated at the base of the wall. Use appropriate fastener for each substrate.

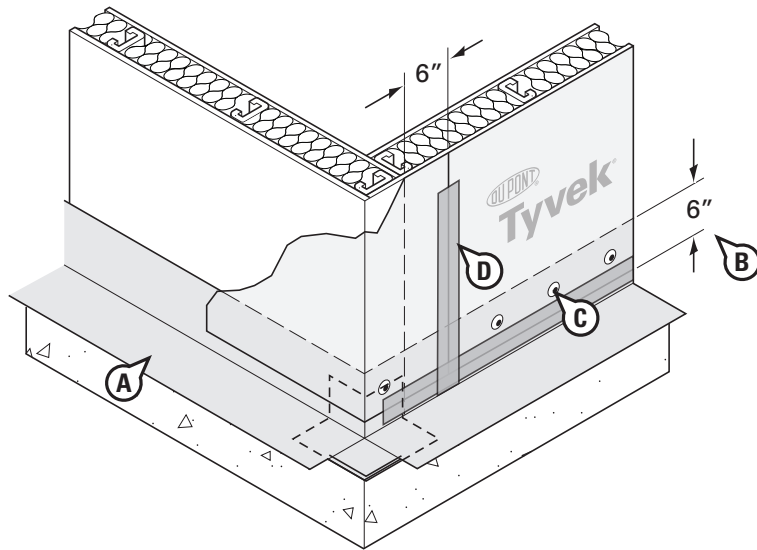

#### Shelf angle

- Through wall flashing should be applied to the top of the shelf angle and the DuPont™ Tyvek® air and water barrier should be properly shingled over by at least 6".
- Seal the DuPont™ Tyvek® air and water barrier to the bottom of the shelf angle using DuPont™ self-adhered flashing products.
- Seal bottom of the DuPont™ Tyvek® air and water barrier to through wall flashing using 3" DuPont™ Tyvek® Tape or a DuPont™ self-adhered flashing product.

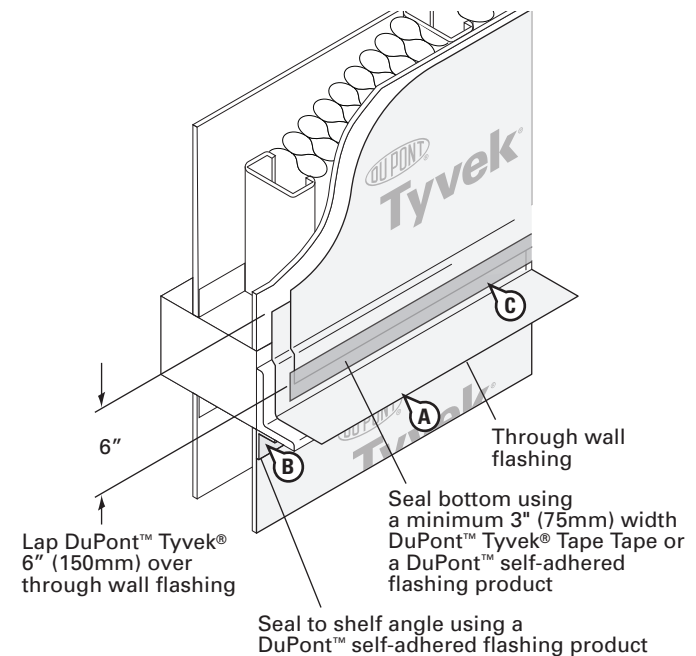

## DuPont Self-Adhered Flashing Systems Installation Guidelines

### Parapet wall with brick

- A. Apply DuPont™ Adhesive/Primer to wall surface or sheathing and install a minimum 4" DuPont™ StraightFlash™.
- B. Install roofing membrane
- C. Install through wall flashing over parapet wall, overlapping the DuPont™ Tyvek® air and water barrier and the roofing membrane by a minimum of 4" in the proper shingling manner.
- D. Install DuPont™ StraightFlash™ or DuPont™ Flashing Tape patches behind brick tie base plate.
- E. Install coping cap.

**NOTE:** Additional CAD details are available in the Technical Information section of [www.weatherization.tyvek.com](http://www.weatherization.tyvek.com).

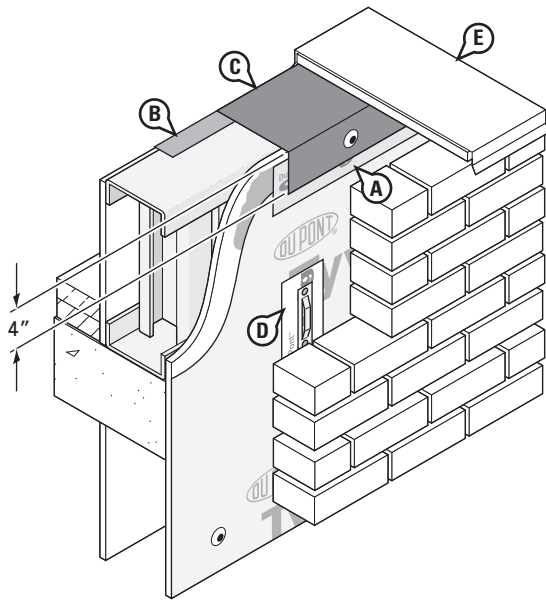

## DuPont Self-Adhered Flashing Systems Installation Guidelines

### Penetrations

Seal around plumbing pipes, HVAC components, electrical outlets, exterior lights, flashing panels, and other objects that penetrate the DuPont™ Tyvek® air and water barrier. Always use positive shingling by installing DuPont™ Tyvek® air and water barriers and self-adhered flashing products from bottom to top, with upper layer installed over lower layer.

**OPTIONAL LAST STEP FOR ALL INSTALLATIONS:** Install a piece of DuPont™ Tyvek® air and water barrier and seal with DuPont™ Tyvek® Tape to overlap the top edge of the DuPont™ Self-Adhered Flashing product (shown below).

### Flashing Integral Flanged Products AFTER Installation of DuPont™ Tyvek® Air and Water Barrier

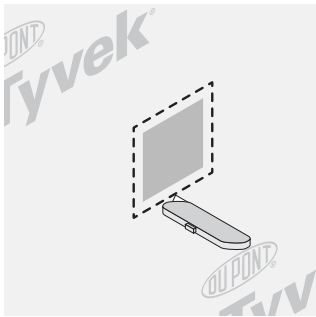

#### STEP 1

Install DuPont™ Tyvek® air and water barrier and cut as necessary to accommodate integral flanged product.

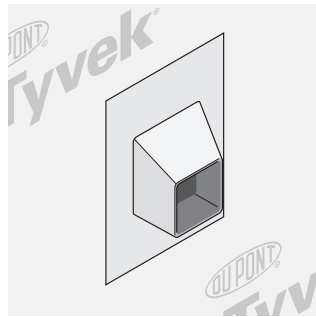

#### STEP 2

Install integral flanged product per manufacturer's instructions.

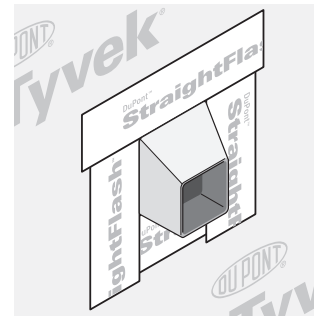

#### STEP 3

Install DuPont™ StraightFlash™ or DuPont™ Flashing Tape\* onto flanges, extending onto DuPont™ Tyvek® air and water barrier by a minimum of 2".

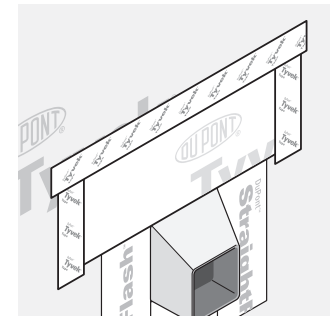

#### STEP 4 (OPTIONAL)

Install a piece of DuPont™ Tyvek® air and water barrier to overlap the top edge of the DuPont™ StraightFlash™. Seal sides and top with DuPont™ Tyvek® Tape

\*DuPont™ Flashing Tape is only permitted for Residential-Use building structures. Residential-Use (Group R) is defined by the 2015/2018 International Building Code.

## DuPont Self-Adhered Flashing Systems Installation Guidelines

### Option 1: Flashing Non-Flanged AFTER Installation of DuPont™ Tyvek® Air and Water Barrier Using DuPont™ FlexWrap™ EZ

Use DuPont™ FlexWrap™ EZ only when penetration rough opening (RO) is not more than ½" larger than the outside diameter/dimension (OD) of non-flanged product.

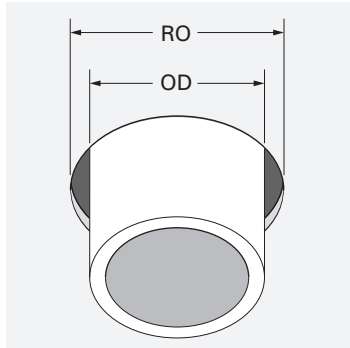

### For non-flanged products with OD GREATER than 2"

#### STEP 1

Install DuPont™ Tyvek® air and water barrier over non-flanged product and cut around penetration.

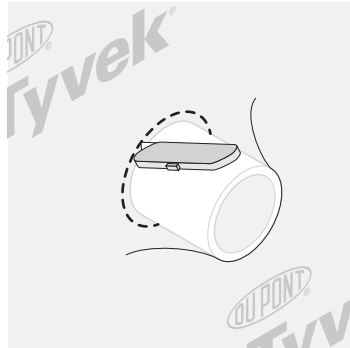

#### STEP 2

Cut a piece of DuPont™ FlexWrap™ EZ longer than circumference of non-flanged product to ensure a minimum 1" overlap onto the DuPont™ Tyvek® air and water barrier. Starting at the horizontal position on either side, adhere around penetration and onto DuPont™ Tyvek® air and water barrier.

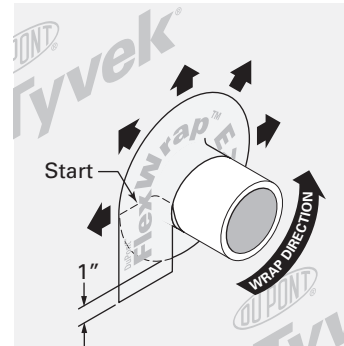

### For non-flanged products with OD LESS than 2"

#### STEP 1

Install DuPont™ Tyvek® air and water barrier over non-flanged product and cut around penetration.



#### STEP 2

Cut a piece of DuPont™ FlexWrap™ EZ the length of ½ the circumference of the non-flanged product. Adhere onto bottom section and fan out onto DuPont™ Tyvek® air and water barrier.

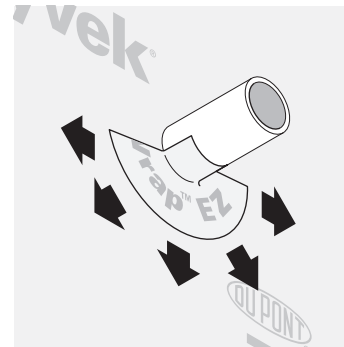

#### STEP 3

Cut a second piece of DuPont™ FlexWrap™ EZ the length of the pipe circumference. Adhere onto top section and fan out onto face of wall with a minimum of 1" overlap of the edges of DuPont™ FlexWrap™ EZ below.

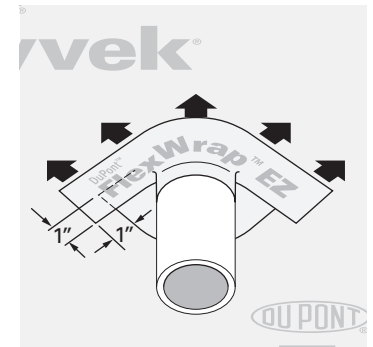



## DuPont Self-Adhered Flashing Systems Installation Guidelines

### Option 2: Flashing Non-Flanged Products AFTER Installation of DuPont™ Tyvek® Air and Water Barrier Using DuPont™ FlexWrap™ NF

#### STEP 1

Install DuPont™ Tyvek® air and water barrier over non-flanged product and cut around penetration.



#### STEP 2

Working counterclockwise, install DuPont™ FlexWrap™ NF around penetration with a minimum 2" overlap.

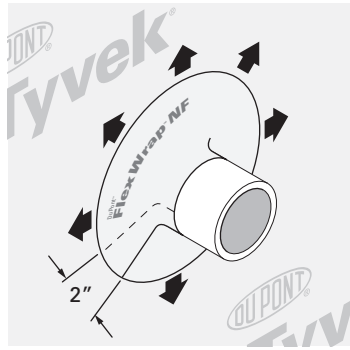

## DuPont Self-Adhered Flashing Systems Installation Guidelines

### Flashing Integral Flanged Products BEFORE Installation of DuPont™ Tyvek® Air and Water Barrier

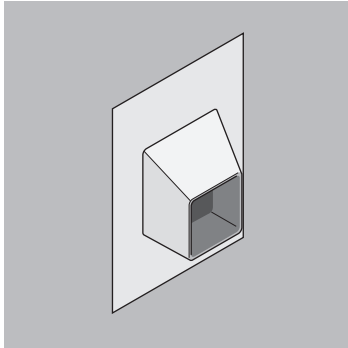

**STEP 1**  
Install integral flanged product onto sheathing per manufacturer's instructions.

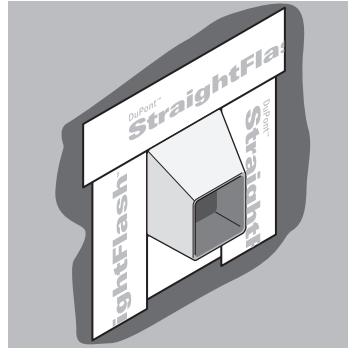

**STEP 2**  
Prime as necessary with DuPont™ Adhesive/Primer. Install DuPont™ StraightFlash™ or DuPont™ Flashing Tape\* onto flanges, extending onto sheathing by a minimum of 2".

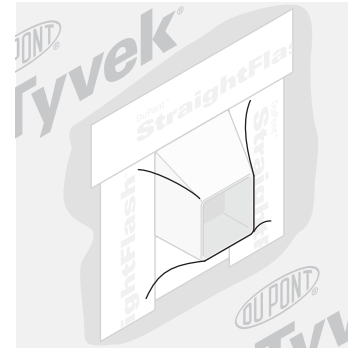

**STEP 3**  
Install DuPont™ Tyvek® air and water barrier.

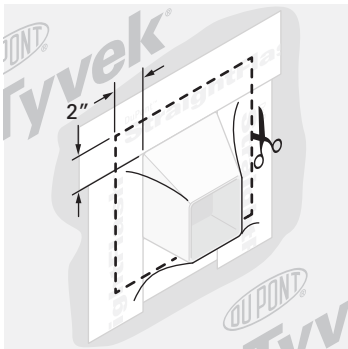

**STEP 4**  
Make cut in DuPont™ Tyvek® air and water barrier, ensuring a minimum of 2" gap for adhesion of DuPont™ StraightFlash™.

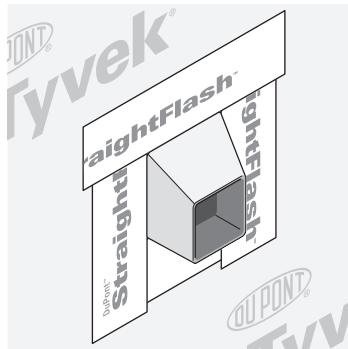

**STEP 5**  
Seal edges of DuPont™ Tyvek® air and water barrier with DuPont™ StraightFlash™.

\*DuPont™ Flashing Tape is only permitted for Residential-Use building structures. Residential-Use (Group R) is defined by the 2015/2018 International Building Code.

## DuPont Self-Adhered Flashing Systems Installation Guidelines

### Proper overlap for water management

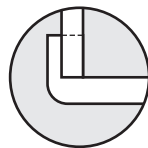
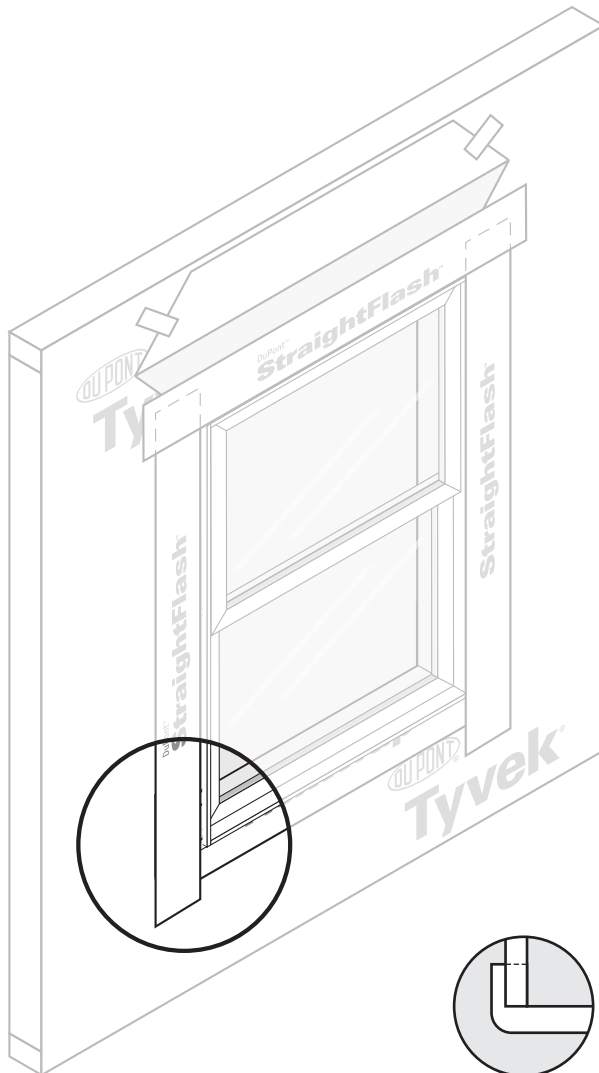

**INCORRECT**  
DuPont™ FlexWrap™ NF  
reverse flashed

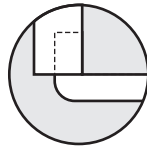

**CORRECT**  
DuPont™ StraightFlash™  
overlaps DuPont™  
FlexWrap™ NF

**NOTE:** In order to make a claim under the DuPont Weatherization Products 10-Year Limited Product and Labor Warranty, you must have met all of the terms and conditions of the warranty, including use of the applicable DuPont Installation Guidelines. In the event that a specific detail or installation technique is not covered in the DuPont Installation Guidelines at the time you are building, then the Key Installation Requirements outlined in this document must have been followed in order to make a claim under the warranty. Compliance prior, during and post construction with the Key Installation Requirements are at the sole discretion of DuPont. Please contact DuPont or a DuPont™ Tyvek® Specialist if you have any questions in connection with any DuPont Installation Guideline.

## Technical Specifications

DuPont™ Tyvek® air and water barriers used in construction products are made from 100% flash spunbonded high density polyethylene fibers which have been bonded together by heat and pressure, without binders or fillers, into a tough durable sheet structure. Additives have been incorporated into the polyethylene to provide ultraviolet light resistance. DuPont requires that DuPont™ Tyvek® CommercialWrap® and CommercialWrap® D be covered within nine months (270 days) of installation.

DuPont™ self-adhered flashing products are made from a synthetic rubber adhesive and a laminate of polyethylene film, polypropylene film, elastic fiber, synthetic rubber adhesive, polyurethane adhesive, and a top sheet of flash spunbonded high density polyethylene fibers or polypropylene film. Additives have been incorporated into these materials to provide ultraviolet light resistance. DuPont requires that DuPont™ FlexWrap™ EZ, FlexWrap™ NF, StraightFlash™ and StraightFlash™ VF be covered within nine months (270 days) of installation. DuPont requires that DuPont™ Flashing Tape be covered within four months (120 days) of installation.

## Warning

**DuPont™ Tyvek® air and water barriers are slippery and should not be used in any application where they will be walked on. In addition, because they are slippery, DuPont recommends using kickjacks, scaffolding, or lifts for exterior work above the first floor. If ladders must be used, extra caution must be taken to use them safely by following the requirements set forth in ANSI Standards 14.1, 14.2, and 14.5 for ladders made of wood, aluminum, and fiberglass, respectively. DuPont™ Tyvek® is combustible and should be protected from flames and other high heat sources. DuPont™ Tyvek® will melt at 275°F (135°C) and if the temperature of DuPont™ Tyvek® reaches 750°F (400°C), it will burn and the fire may spread and fall away from the point of ignition. For more information, call 1-800-44-Tyvek.**

**DuPont™ self-adhered flashing products and their release paper are slippery and should not be walked on. Remove release paper from work area immediately. DuPont™ Flashing Systems products will melt at temperatures greater than 250°F (121°C). DuPont™ Flashing Systems products are combustible and should be protected from flames and other high heat sources. DuPont™ Flashing Systems products will not support combustion if the heat source is removed. However, if burning occurs, ignited droplets may fall away from the point of ignition. For more information, call 1-800-44-Tyvek.**

## Note

When installed in conjunction with other building materials, DuPont™ self-adhered flashing products must be properly shingled with these materials such that water is diverted to the exterior of the wall system. DuPont™ Tyvek® products are air and water barriers and not the primary water barrier. The outer facade is the primary barrier. You must follow facade manufacturer's installation and maintenance requirements for all facade systems in order to maintain water holdout properties and ensure performance of DuPont™ Tyvek® air and water barriers. Use of additives, coatings or cleansers on or in the facade system may impact the performance of DuPont™ Tyvek® air and water barriers. DuPont™ Tyvek® Weatherization Systems products are to be used as outlined in this installation guideline. DuPont™ self-adhered flashing products should only be used to seal penetrations and flash openings in houses or buildings. DuPont™ self-adhered flashing products are not to be used in roofing applications. For superior protection against bulk water penetration, DuPont suggests a system combining a quality exterior facade, a good secondary air and water barrier and exterior sheathing, high quality windows and doors, and appropriate flashing materials paying attention to proper installation of each component. In a system where no exterior sheathing is used and DuPont™ Tyvek® air and water barrier is installed directly over the wall studs, exterior facade materials should be selected to ensure maximum protection against water intrusion. Careful workmanship and proper installation of each component is very important.

DuPont believes this information to be reliable and accurate. The information may be subject to revision as additional experience and knowledge is gained. It is the user's responsibility to determine the proper construction materials needed.

For complete warranty information please call 1-800-44-Tyvek.

This information is not intended to be used by others for advertising, promotion, or other publication for commercial purposes.

For more information about DuPont Weatherization Systems, please call 1-800-44-Tyvek or visit us at [www.weatherization.tyvek.com](http://www.weatherization.tyvek.com)



The Tyvek logo features the word "Tyvek" in a blue, sans-serif font. Above the text is a horizontal bar composed of several colored segments: blue, white, grey, and black. A registered trademark symbol (®) is located to the upper right of the word "Tyvek".